

FEATURES

Compatible with Microsoft[®] PC 97 Logo Requirements
 Supports Applications Written for Windows[®] 95,
 Windows 3.1, Windows NT, SoundBlaster[®] Pro,
 AdLib[®]/OPL3[®]

Stereo Audio 16-Bit $\Sigma\Delta$ Codec
 Internal 3D Circuit—Phat[™] Stereo Phase Expander
 MPC Level-3 Mixer
 ISA Plug and Play Compatible
 16-Bit Address Decode
 Dual Type F FIFO DMA Support
 MPU-401 Compatible MIDI Port
 Supports Wavetable Synthesizers
 Integrated Enhanced Digital Game Port
 Bidirectional DSP Serial Port
 Two I²S Digital Audio Serial Ports

Integrated OPL3 Compatible Music Synthesizer
 Software and Hardware Volume Control
 Full-Duplex Capture and Playback Operation at
 Different Sample Rates
 Supports Up to Six Different Sample Rates Simultaneously
 1 Hz Resolution Programmable Sample Rates from
 4 kHz to 55.2 kHz
 Power Management Modes
 Operation from +5 V Supply
 Built-In 24 mA Bus Drivers
 100-Lead PQFP and TQFP Package



FUNCTIONAL BLOCK DIAGRAM

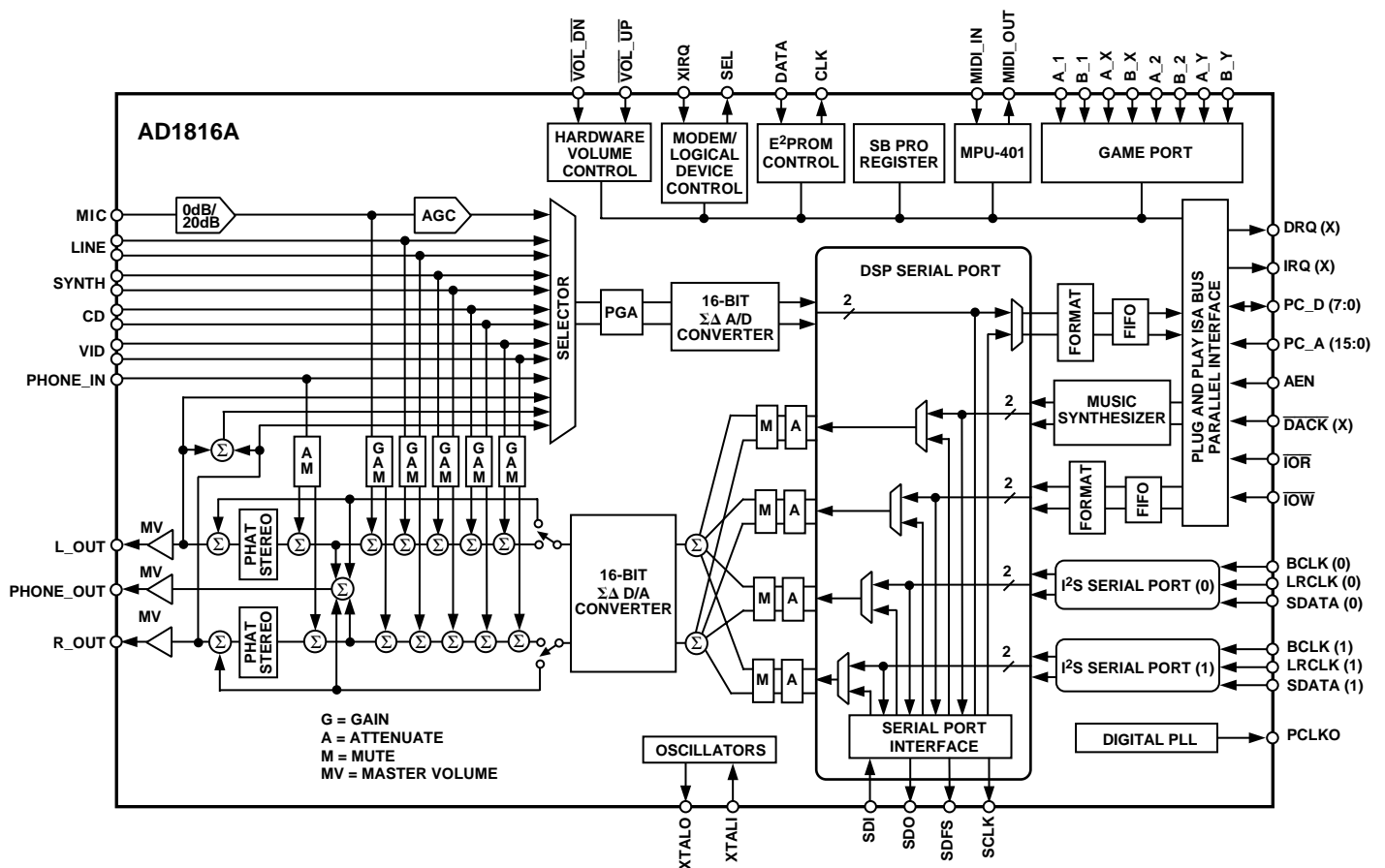

SoundPort is a registered trademark of Analog Devices, Inc.
 Phat is a trademark of Analog Devices, Inc.
 All other trademarks are the property of their respective holders.

REV. A

Information furnished by Analog Devices is believed to be accurate and reliable. However, no responsibility is assumed by Analog Devices for its use, nor for any infringements of patents or other rights of third parties which may result from its use. No license is granted by implication or otherwise under any patent or patent rights of Analog Devices.

One Technology Way, P.O. Box 9106, Norwood, MA 02062-9106, U.S.A.
 Tel: 781/329-4700 World Wide Web Site: <http://www.analog.com>
 Fax: 781/326-8703 © Analog Devices, Inc., 1997

AD1816A

PRODUCT OVERVIEW

The AD1816A SoundPort Controller is a single chip Plug and Play multimedia audio subsystem for concurrently processing multiple digital streams of 16-bit stereo audio in personal computers. The AD1816A maintains full legacy compatibility with applications written for SoundBlaster Pro and AdLib, while servicing Microsoft PC 97 application requirements. The AD1816A includes an internal OPL3 compatible music synthesizer, Phat

Stereo circuitry for phase expanding the analog stereo output, an MPU-401 UART, joystick interface with a built-in timer, a DSP serial port and two I²S serial ports. The AD1816A on-chip Plug and Play routine provides configuration services for all integrated logical devices. Using an external E²PROM allows the AD1816A to decode up to two additional external user-defined logical devices such as modem and CD-ROM.

TABLE OF CONTENTS

FEATURES	1	Figures	
PRODUCT OVERVIEW	2	Functional Block Diagram	1
SPECIFICATIONS	3	Figure 1. PIO Read Cycle	6
PIN CONFIGURATION	9	Figure 2. PIO Write Cycle	6
PIN FUNCTION DESCRIPTIONS	11	Figure 3. DMA Read Cycle	7
HOST INTERFACE	15	Figure 4. DMA Write Cycle	7
REFERENCES	16	Figure 5. Codec Transfers	7
SERIAL INTERFACES	17	Figure 6. DSP Port Timing	7
ISA INTERFACE	21	Figure 7. I ² S Serial Port Timing	7
AD1816A Chip Registers	21	Figure 8. Reset Pulse Width	7
AD1816A Plug and Play Device Configuration Registers ..	22	Figure 9. Serial Interface Right-Justified Mode	17
Sound System Direct Registers	23	Figure 10. Serial Interface I ² S-Justified Mode	17
Sound System Indirect Registers	29	Figure 11. Serial Interface Left-Justified Mode	17
SB Pro; AdLib Registers	38	Figure 12. DSP Serial Interface (Default Frame Rate)	20
MPU-401 Registers	39	Figure 13. DSP Serial Interface (User Programmed	
Game Port Register	39	Frame Rate)	20
APPENDIX A.		Figure 14. DSP Serial Port	21
PLUG AND PLAY INTERNAL ROM	40	Figure 15. Codec Transfers	27
PLUG AND PLAY KEY AND "ALTERNATE KEY"		Figure 16. Recommended Application Circuit	48
SEQUENCES	41	Figure 17. AD1816A Frequency Response Plots	49
AD1816 AND AD1816A COMPATIBILITY	42	Tables	
USING AN EEPROM WITH THE AD1816 OR		Table I. DSP Port Time Slot Map	18
AD1816A	42	Table II. Chip Register Diagram	21
AD1816 FLAG BYTE	42	Table III. Logical Devices and Compatible Plug and	
USING THE AD1816 WITHOUT AN EEPROM	42	Play Device Drivers	22
AD1816A FLAG BYTES	43	Table IV. Internal Logical Device Configuration	23
USING THE AD1816A WITHOUT AN EEPROM	44	Table V. Sound System Direct Registers	23
MAPPING THE AD1816 EEPROM INTO THE		Table VI. Codec Transfers	27
AD1816A EEPROM	45	Table VII. Indirect Register Map and Reset/Default States .	30
PIN MUXING IN THE AD1816 AND AD1816A	45	Table VIII. Sound System Indirect Registers	31
PROGRAMMING EXTERNAL EEPROMS	47	Table IX. SoundBlaster Pro ISA Bus Registers	38
REFERENCE DESIGNS AND DEVICE DRIVERS ...	47	Table X. AdLib ISA Bus Registers	39
OUTLINE DIMENSIONS	50	Table XI. MIDI ISA Bus Registers	39
		Table XII. Game Port ISA Bus Registers	39
		Table XIII. AD1816 Pin Muxing	45
		Table XIV. AD1816A Pin Muxing	46

SPECIFICATIONS

STANDARD TEST CONDITIONS UNLESS OTHERWISE NOTED

Temperature	25	°C
Digital Supply (V_{DD})	5.0	V
Analog Supply (V_{CC})	5.0	V
Sample Rate (F_S)	48	kHz
Input Signal Frequency	1008	Hz
Audio Output Passband	20 Hz to 20 kHz	
V_{IH}	5.0	V
V_{IL}	0	V

DAC Test Conditions

0 dB Attenuation
 Input Full Scale
 16-Bit Linear Mode
 100 k Ω Output Load
 Mute Off
 Measured at Line Output

ADC Test Conditions

0 dB Gain
 Input -4 dB Relative to Full Scale
 Line Input Selected
 16-Bit Linear Mode

ANALOG INPUT

Parameter	Min	Typ	Max	Units
Full-Scale Input Voltage (RMS Values Assume Sine Wave Input) PHONE_IN, LINE, SYNTH, CD, VID		1		V rms
		2.83		V p-p
MIC with +20 dB Gain (MGE = 1)		0.1		V rms
		0.283		V p-p
MIC with 0 dB Gain (MGE = 0)		1		V rms
		2.83		V p-p
Input Impedance*		17		k Ω
Input Capacitance*		15		pF

PROGRAMMABLE GAIN AMPLIFIER—ADC

Parameter	Min	Typ	Max	Units
Step Size (0 dB to 22.5 dB) (All Steps Tested)		1.5		dB
PGA Gain Range Span		22.5		dB

CD, LINE, MICROPHONE, SYNTHESIZER, AND VIDEO INPUT ANALOG GAIN/ATTENUATORS/MUTE AT LINE OUTPUT

Parameter	Min	Typ	Max	Units
CD, LINE, MIC, SYNTH, VID				
Step Size: (All Steps Tested) +12 dB to -34.5 dB		1.5		dB
Input Gain/Attenuation Range		46.5		dB
PHONE_IN				
Step Size 0 dB to -45 dB: (All Steps Tested)		3.0		dB
Input Gain/Attenuation Range		45		dB

AD1816A

DIGITAL DECIMATION AND INTERPOLATION FILTERS*

Parameter	Min	Typ	Max	Units
Audio Passband	0		$0.4 \times F_S$	Hz
Audio Passband Ripple			± 0.09	dB
Audio Transition Band	$0.4 \times F_S$		$0.6 \times F_S$	Hz
Audio Stopband	$0.6 \times F_S$		∞	Hz
Audio Stopband Rejection	82			dB
Audio Group Delay			$12/F_S$	sec
Group Delay Variation Over Passband			0.0	μ s

ANALOG-TO-DIGITAL CONVERTERS

Parameter	Min	Typ	Max	Units
Resolution		16		Bits
Signal-to-Noise Ratio (SNR) (A-Weighted, Referenced to Full Scale)		82	80	dB
Total Harmonic Distortion (THD) (Referenced to Full Scale)		0.011	0.015	%
		-79	-76.5	dB
Audio Dynamic Range (-60 dB Input THD+N Referenced to Full-Scale, A-Weighted)	79	82		dB
Audio THD+N (Referenced to Full-Scale)			0.019	%
		-76	-74.5	dB
Signal-to-Intermodulation Distortion* (CCIF Method)		82		dB
ADC Crosstalk*				
Line Inputs (Input L, Ground R, Read R; Input R, Ground L, Read L)		-95	-80	dB
Line to MIC (Input LINE, Ground and Select MIC, Read ADC)		-95	-80	dB
Line to SYNTH		-95	-80	dB
Line to CD		-95	-80	dB
Line to VID		-95	-80	dB
Gain Error (Full-Scale Span Relative to Nominal Input Voltage)			± 10	%
Interchannel Gain Mismatch (Difference of Gain Errors)			± 1	dB
ADC Offset Error	-22		+15	mV

DIGITAL-TO-ANALOG CONVERTERS

Parameter	Min	Typ	Max	Units
Resolution		16		Bits
Signal-to-Noise Ratio (SNR) (A-Weighted)		83	79	dB
Total Harmonic Distortion (THD)		0.006	0.009	%
		-85	-80.5	dB
Audio Dynamic Range (-60 dB Input THD+N Referenced to Full Scale, A-Weighted)	79	82		dB
Audio THD+N (Referenced to Full Scale)		0.013	0.017	%
		-78	-75.5	dB
Signal-to-Intermodulation Distortion* (CCIF Method)		95		dB
Gain Error (Full-Scale Span Relative to Nominal Input Voltage)			± 10	%
Interchannel Gain Mismatch (Difference of Gain Errors)			± 0.5	dB
DAC Crosstalk* (Input L, Zero R, Measure R_OUT; Input R, Zero L, Measure L_OUT)			-80	dB
Total Out-of-Band Energy (Measured from $0.6 \times F_S$ to 100 kHz at L_OUT and R_OUT)*			-45	dB
Audible Out-of-Band Energy (Measured from $0.6 \times F_S$ to 20 kHz at L_OUT and R_OUT)*			-75	dB

MASTER VOLUME ATTENUATORS (L_OUT AND R_OUT, PHONE_OUT)

Parameter	Min	Typ	Max	Units
Master Volume Step Size (0 dB to -46.5 dB)		1.5		dB
Master Volume Output Attenuation Range Span		46.5		dB
Mute Attenuation of 0 dB Fundamental*			-80	dB

DIGITAL MIX ATTENUATORS*

Parameter	Min	Typ	Max	Units
Step Size: I ² S (0), I ² S (1), Music, ISA		1.505		dB
Digital Mix Attenuation Range Span		94.8		dB

ANALOG OUTPUT

Parameter	Min	Typ	Max	Units
Full-Scale Output Voltage (at L_OUT, R_OUT, PHONE_OUT)		2.8		V p-p
Output Impedance*			570	Ω
External Load Impedance*	10			k Ω
Output Capacitance*		15		pF
External Load Capacitance			100	pF
V _{REFX} *	2.10	2.25	2.40	V
V _{REFX} Current Drive*		100		μ A
V _{REFX} Output Impedance*		6.5		k Ω
Master Volume Mute Click (Muted Analog Mixers), Muted Output Minus Unmuted Output at 0 dB		\pm 5		mV

SYSTEM SPECIFICATIONS*

Parameter	Min	Typ	Max	Units
System Frequency Response Ripple (Line In to Line Out)			1.0	dB
Differential Nonlinearity			\pm 1	LSB
Phase Linearity Deviation			5	Degrees

STATIC DIGITAL SPECIFICATIONS

Parameter	Min	Typ	Max	Units
High Level Input Voltage (V _{IH})	2			V
XTALI	2.4			V
Low Level Input Voltage (V _{IL})			0.8	V
High Level Output Voltage (V _{OH}), I _{OH} = 8 mA [†]	2.4			V
Low Level Output Voltage (V _{OL}), I _{OL} = 8 mA			0.4	V
Input Leakage Current	-10		+10	μ A
Output Leakage Current	-10		+10	μ A

POWER SUPPLY

Parameter	Min	Typ	Max	Units
Power Supply Range—Analog	4.75		5.25	V
Power Supply Range—Digital	4.75		5.25	V
Power Supply Current			221	mA
Power Dissipation			1105	mW
Analog Supply Current			51	mA
Digital Supply Current			170	mA
Analog Power Supply Current—Power-Down			2	mA
Digital Power Supply Current—Power-Down			24	mA
Analog Power Supply Current—RESET			0.2	mA
Digital Power Supply Current—RESET			10	mA
Power Supply Rejection (100 mV p-p Signal on Both Analog and Digital Supply Pins, Measured at ADC and Line Outputs)		40		dB

CLOCK SPECIFICATIONS*

Parameter	Min	Typ	Max	Units
Input Clock Frequency		33		MHz
Recommended Clock Duty Cycle	25	50	75	%
Power-Up Initialization Time			500	ms

AD1816A

TIMING PARAMETERS (Guaranteed Over Operating Temperature Range)

Parameter	Symbol	Min	Typ	Max	Units
$\overline{\text{IOW}}/\overline{\text{IOR}}$ Strobe Width	t_{STW}	100			ns
$\overline{\text{IOW}}/\overline{\text{IOR}}$ Rising to $\overline{\text{IOW}}/\overline{\text{IOR}}$ Falling	t_{BWDN}	80			ns
Write Data Setup to $\overline{\text{IOW}}$ Rising	t_{WDSU}	10			ns
$\overline{\text{IOW}}$ Falling to Valid Read Data	t_{RDDV}			40	ns
AEN Setup to $\overline{\text{IOW}}/\overline{\text{IOR}}$ Falling	t_{AESU}	10			ns
AEN Hold from $\overline{\text{IOW}}/\overline{\text{IOR}}$ Rising	t_{AEHD}	0			ns
Adr Setup to $\overline{\text{IOW}}/\overline{\text{IOR}}$ Falling	t_{ADSU}	10			ns
Adr Hold from $\overline{\text{IOW}}/\overline{\text{IOR}}$ Rising	t_{ADHD}	0			ns
$\overline{\text{DACK}}$ Rising to $\overline{\text{IOW}}/\overline{\text{IOR}}$ Falling	t_{DKSU}	20			ns
Data Hold from $\overline{\text{IOR}}$ Rising	t_{DHD1}			2	ns
Data Hold from $\overline{\text{IOW}}$ Rising	t_{DHD2}	15			ns
DRQ Hold from $\overline{\text{IOW}}/\overline{\text{IOR}}$ Falling	t_{DRHD}			25	ns
$\overline{\text{DACK}}$ Hold from $\overline{\text{IOW}}/\overline{\text{IOR}}$ Rising	t_{DKHD}	10			ns
Data [SDI] Input Setup Time to SCLK*	t_{S}	15			ns
Data [SDI] Input Hold Time from SCLK*	t_{H}	10			ns
Frame Sync [SDFS] HI Pulse Width*	t_{FSW}		80		ns
Clock [SCLK] to Frame Sync [SDFS] Propagation Delay*	t_{PD}			15	ns
Clock [SCLK] to Output Data [SDO] Valid*	t_{DV}			15	ns
$\overline{\text{RESET}}$ Pulse Width	t_{RPWL}	100			ns
BCLK HI Pulse Width	t_{DBH}	25			ns
BCLK LO Pulse Width	t_{DBL}	25			ns
BCLK Period	t_{DBP}	50			ns
LRCLK Setup	t_{DLS}	5			ns
SDATA Setup	t_{DDS}	5			ns
SDATA Hold	t_{DDH}	5			ns

NOTES

*Guaranteed, not tested.

†All ISA pins MIDI_OUT IOL = 24 mA. Refer to pin description for individual output drive levels.

Specifications subject to change without notice.

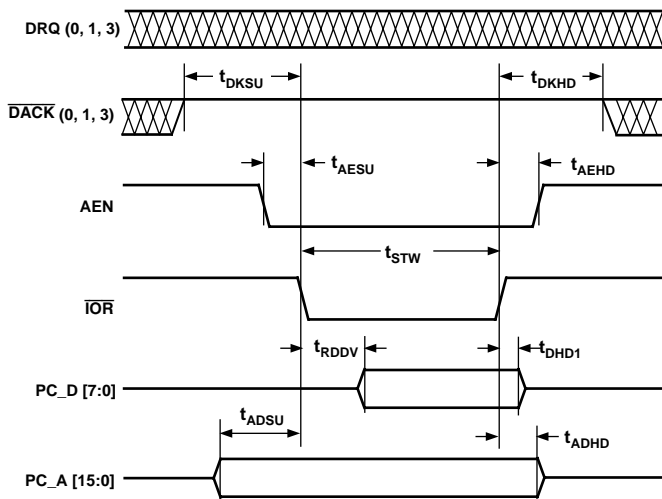

Figure 1. PIO Read Cycle

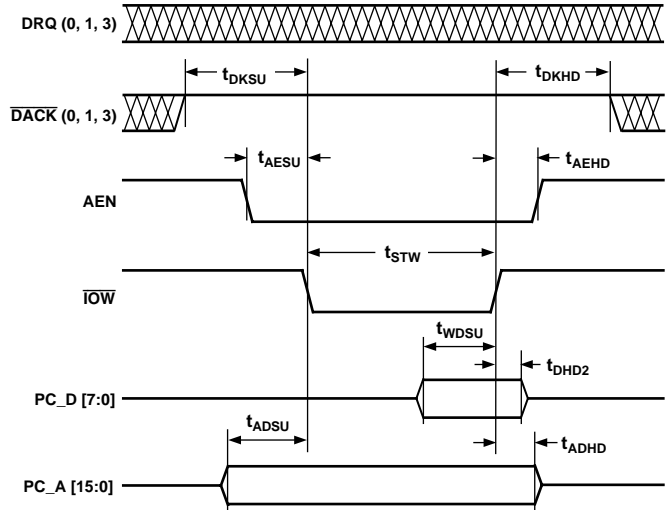

Figure 2. PIO Write Cycle

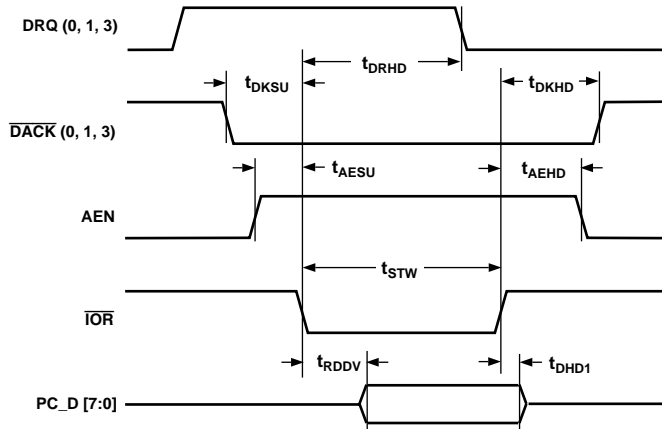

Figure 3. DMA Read Cycle

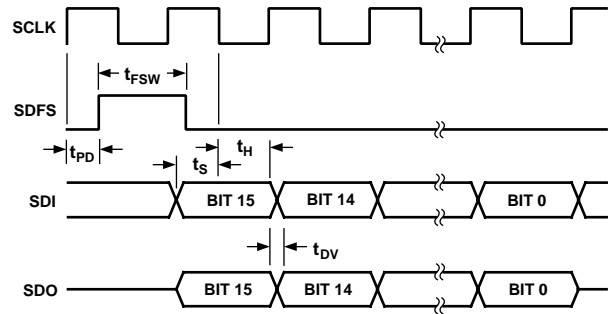

Figure 6. DSP Port Timing

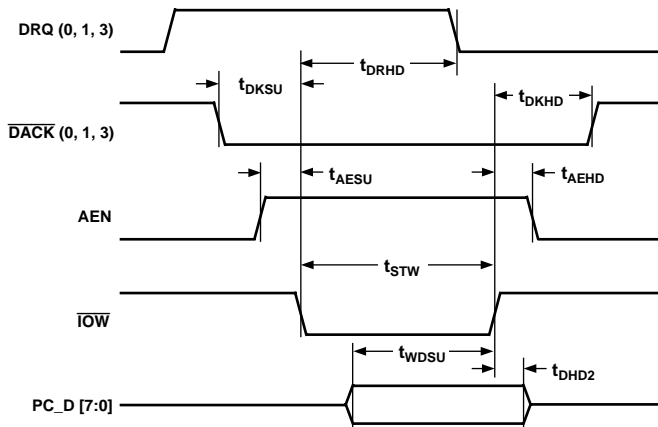

Figure 4. DMA Write Cycle

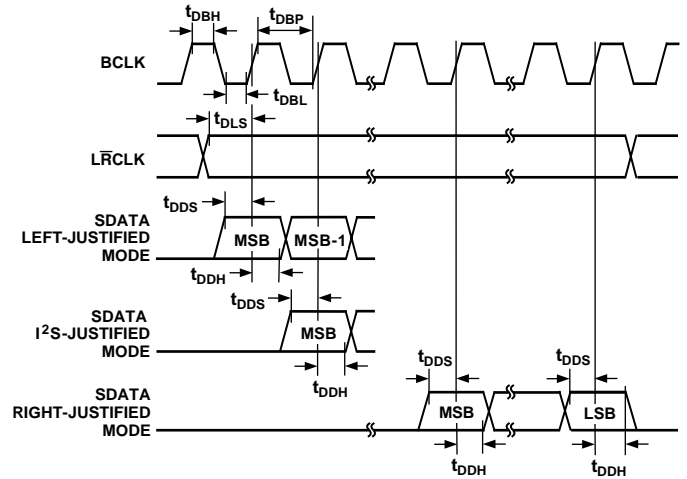

Figure 7. I²S Serial Port Timing

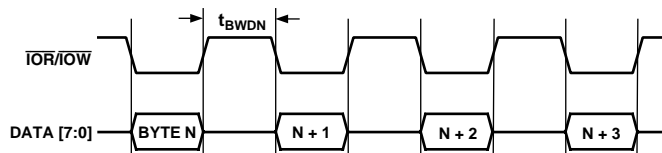

Figure 5. Codec Transfers

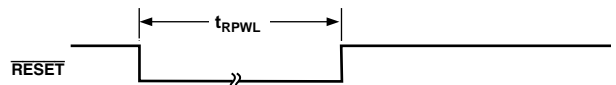

Figure 8. Reset Pulse Width

AD1816A

ABSOLUTE MAXIMUM RATINGS*

Parameter	Min	Max	Units
Power Supplies			
Digital (V_{DD})	-0.3	6.0	V
Analog (V_{CC})	-0.3	6.0	V
Input Current (Except Supply Pins)		± 10.0	mA
Analog Input Voltage (Signal Pins)	-0.3	$V_{CC} + 0.3$	V
Digital Input Voltage (Signal Pins)	-0.3	$V_{DD} + 0.3$	V
Ambient Temperature (Operating)	0	+70	$^{\circ}\text{C}$
Storage Temperature	-65	+150	$^{\circ}\text{C}$

*Stresses greater than those listed under Absolute Maximum Ratings may cause permanent damage to the device. This is a stress rating only; functional operation of the device at these or any other conditions above those indicated in the operational section of this specification is not implied. Exposure to absolute maximum rating conditions for extended periods may affect device reliability.

ENVIRONMENTAL CONDITIONS

Ambient Temperature Rating:

$$T_{\text{AMB}} = T_{\text{CASE}} - (\text{PD} \times \theta_{\text{CA}})$$

T_{CASE} = Case Temperature in $^{\circ}\text{C}$

PD = Power Dissipation in W

θ_{CA} = Thermal Resistance (Case-to-Ambient)

θ_{JA} = Thermal Resistance (Junction-to-Ambient)

θ_{JC} = Thermal Resistance (Junction-to-Case)

Package	θ_{JA}	θ_{JC}	θ_{CA}
PQFP	35.1 $^{\circ}\text{C}/\text{W}$	7 $^{\circ}\text{C}/\text{W}$	28 $^{\circ}\text{C}/\text{W}$
TQFP	35.3 $^{\circ}\text{C}/\text{W}$	8 $^{\circ}\text{C}/\text{W}$	27.3 $^{\circ}\text{C}/\text{W}$

ORDERING GUIDE

Model	Temperature Range	Package Description	Package Option*
AD1816AJS	0 $^{\circ}\text{C}$ to +70 $^{\circ}\text{C}$	100-Lead PQFP	S-100
AD1816AJST	0 $^{\circ}\text{C}$ to +70 $^{\circ}\text{C}$	100-Lead TQFP	ST-100

*S = Plastic Quad Flatpack; ST = Thin Quad Flatpack. JST package option availability subject to 10,000 PC minimum order quantity.

CAUTION

ESD (electrostatic discharge) sensitive device. Electrostatic charges as high as 4000 V readily accumulate on the human body and test equipment and can discharge without detection. Although the AD1816A features proprietary ESD protection circuitry, permanent damage may occur on devices subjected to high energy electrostatic discharges. Therefore, proper ESD precautions are recommended to avoid performance degradation or loss of functionality.

The AD1816A latchup immunity has been demonstrated at $\geq +100$ mA/ -80 mA on all pins when tested to Industry Standard/JEDEC methods.



PIN CONFIGURATION

100-Lead PQFP
(S-100)

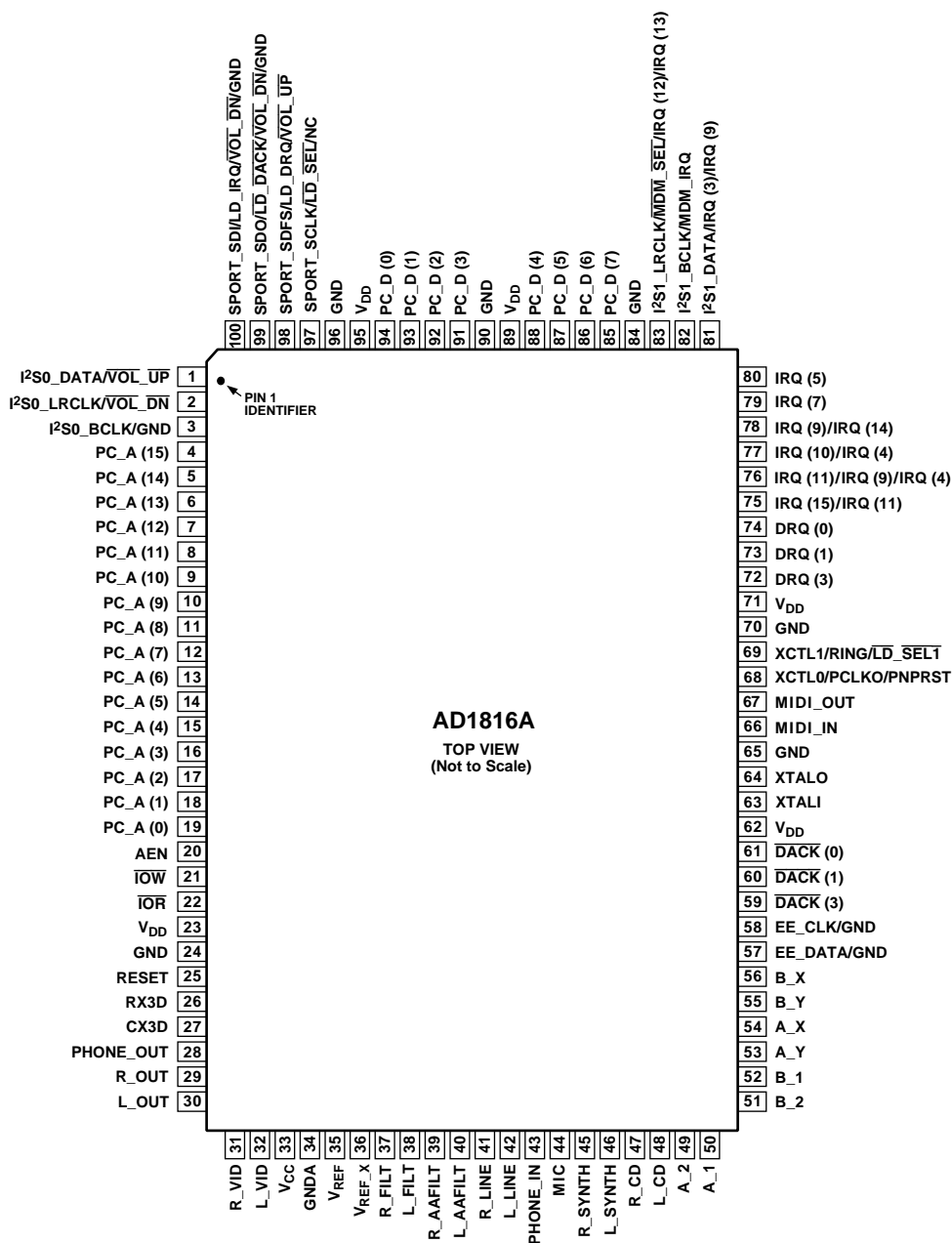

NC = NO CONNECT

PIN CONFIGURATION
100-Lead TQFP
(ST-100)

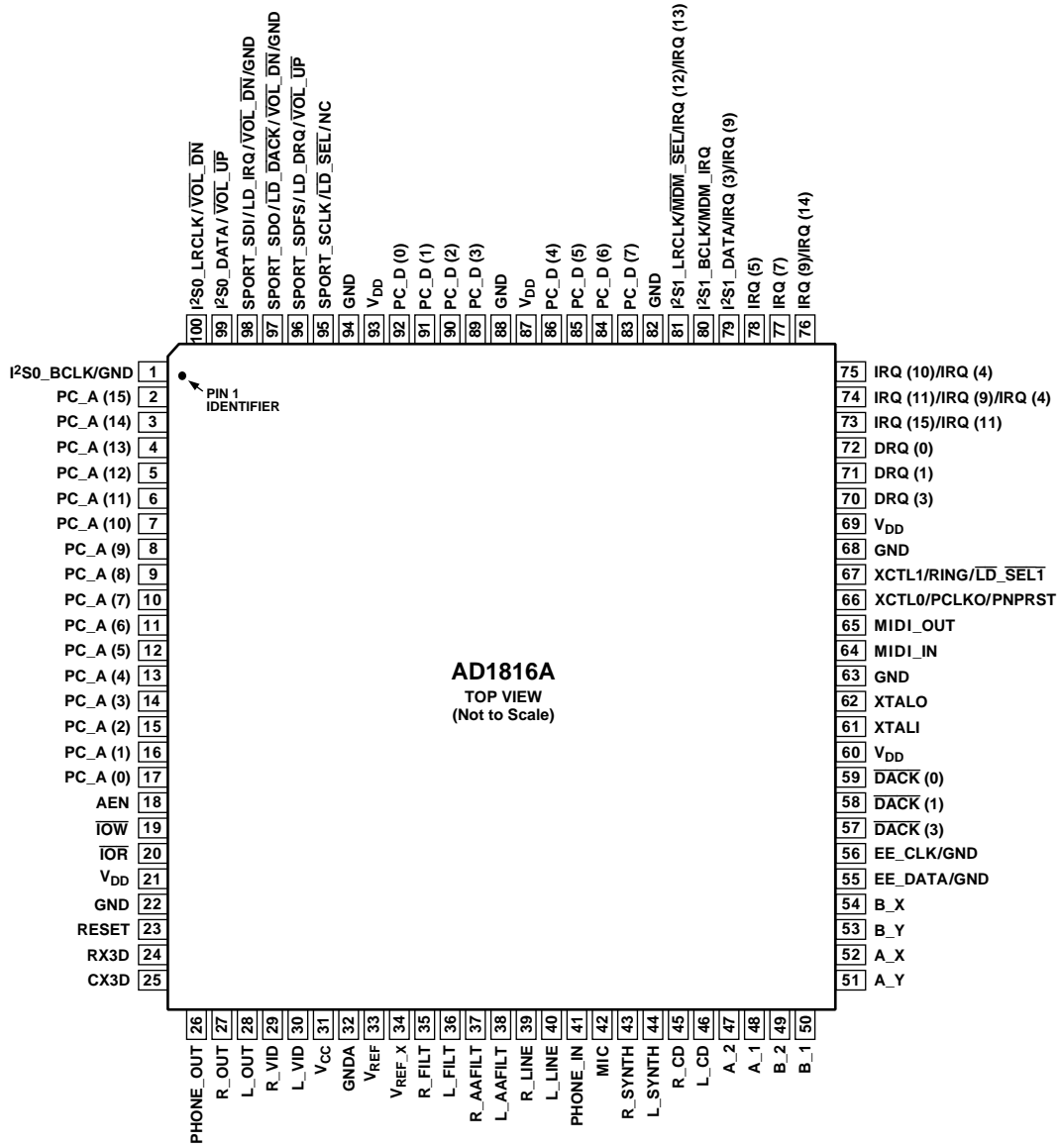

NC = NO CONNECT

PIN FUNCTION DESCRIPTIONS

Analog Signals (All Inputs must be AC-Coupled)

Pin Name	PQFP	TQFP	I/O	Description
MIC	44	42	I	Microphone Input. The MIC input may be either line-level or -20 dB from line-level (the difference being made up through a software controlled 20 dB gain block). The mono MIC input may be sent to the left and right channel of the ADC for conversion, or gained/attenuated from +12 dB to -34.5 dB in 1.5 dB steps and then summed with left and right line OUT before the Master Volume stage.
L_LINE	42	40	I	Left Line-Level Input. The left line-level input may be sent to the left channel of the ADC; gained/attenuated from +12 dB to -34.5 dB in 1.5 dB steps and then summed with left line OUT (L_OUT).
R_LINE	41	39	I	Right Line-Level Input. The right line-level input may be sent to the right channel of the ADC; gained/attenuated from +12 dB to -34.5 dB in 1.5 dB steps and then summed with right line OUT (R_OUT).
L_SYNTH	46	44	I	Left Synthesizer Input. The left MIDI upgrade line-level input may be sent to the left channel of the ADC; gained/attenuated from +12 dB to -34.5 dB in 1.5 dB steps and then summed with left line OUT (L_OUT).
R_SYNTH	45	43	I	Right Synthesizer Input. The right MIDI upgrade line-level input may be sent to the right channel of the ADC; gained/attenuated from +12 dB to -34.5 dB in 1.5 dB steps and then summed with right line OUT (R_OUT).
L_CD	48	46	I	Left CD Line-Level Input. The left CD line-level input may be sent to the left channel of the ADC; gained/attenuated from +12 dB to -34.5 dB in 1.5 dB steps and then summed with left line OUT (L_OUT).
R_CD	47	45	I	Right CD Line-Level Input. The right CD line-level input may be sent to the right channel of the ADC; gained/attenuated from +12 dB to -34.5 dB in 1.5 dB steps and then summed with right line OUT (R_OUT).
L_VID	32	30	I	Left Video Input. The left audio track for a video line-level input may be sent to the left channel of the ADC; gained/attenuated from +12 dB to -34.5 dB in 1.5 dB steps and then summed with left line OUT (L_OUT).
R_VID	31	29	I	Right Video Input. The right audio track for a video line-level input may be sent to the right channel of the ADC; gained/attenuated from +12 dB to -34.5 dB in 1.5 dB steps and then summed with right line OUT (R_OUT).
L_OUT	30	28	O	Left Output. Left channel line-level post-mixed output. The final stage passes through the Master Volume block and may be attenuated 0 dB to -45 dB in 1.5 dB steps.
R_OUT	29	27	O	Right Output. Right channel line-level post-mixed output. The final stage passes through the Master Volume block and may be attenuated 0 dB to -45 dB in 1.5 dB steps.
PHONE_IN	43	41	I	Phone Input. Line-level input from a DAA/modem chipset.
PHONE_OUT	28	26	O	Phone Output. Line-level output from a DAA/modem chipset.
RX3D	26	24	O	Phat Stereo Phase Expander filter network, resistor pin.
CX3D	27	25	I	Phat Stereo Phase Expander filter network, capacitor pin.

AD1816A

Parallel Interface (All Outputs are 24 mA Drivers)

Pin Name	PQFP	TQFP	I/O	Description
PC_D[7:0]	85–88, 91–94	83–86, 89–92	I/O	Bidirectional ISA Bus PC Data, 24 mA drive. Connects the AD1816A to the low byte data on the bus.
IRQ (x)*	75–81, 83	73–79, 81	O	Host Interrupt Request, 24 mA drive. IRQ (3)/IRQ (9), IRQ (5), IRQ (7), IRQ (9)/IRQ (14), IRQ (10)/IRQ (4), IRQ (11)/IRQ (9)/IRQ (4), IRQ (12)/IRQ (13), IRQ (15)/IRQ (11). Active HI signals indicating a pending interrupt.
DRQ (x)	72–74	70–72	O	DMA Request, 24 mA drive. DRQ (0), DRQ (1), DRQ (3). Active HI signals indicating a request for DMA bus operation.
PC_A[15:0]	4–19	2–17	I	ISA Bus PC Address. Connects the AD1816A to the ISA bus address lines.
AEN	20	18	I	Address Enable. Low signal indicates a PIO transfer.
$\overline{\text{DACK}}$ (x)	59–61	57–59	I	DMA Acknowledge. DACK (0), DACK (1), DACK (3). Active LO signal indicating that a DMA operation can begin.
$\overline{\text{IOR}}$	22	20	I	I/O Read. Active LO signal indicates a read operation.
$\overline{\text{IOW}}$	21	19	I	I/O Write. Active HI signal indicates a write operation.
RESET	25	23	I	Reset. Active HI.

Game Port

Pin Name	PQFP	TQFP	I/O	Description
A_1	50	48	I	Game Port A, Button #1.
A_2	49	47	I	Game Port A, Button #2.
A_X	54	52	I	Game Port A, X-Axis.
A_Y	53	51	I	Game Port A, Y-Axis.
B_1	52	50	I	Game Port B, Button #1.
B_2	51	49	I	Game Port B, Button #2.
B_X	56	54	I	Game Port B, X-Axis.
B_Y	55	53	I	Game Port B, Y-Axis.

MIDI Interface Signal (24 mA Drivers)

Pin Name	PQFP	TQFP	I/O	Description
MIDI_IN	66	64	I	RXD MIDI Input. This pin is typically connected to Pin 15 of the game port connector.
MIDI_OUT	67	65	O	TXD MIDI Output. This pin is typically connected to Pin 12 of the game port connector.

Muxed Serial Ports (8 mA Drivers)

Pin Name	PQFP	TQFP	I/O	Description
I ² S(0)_BCLK*	3	1	I	I ² S (0) Bit Clock.
I ² S(0)_LRCLK*	2	100	I	I ² S (0) Left/Right Clock.
I ² S(0)_DATA*	1	99	I	I ² S (0) Serial Data Input.
I ² S(1)_BCLK*	82	80	I	I ² S (1) Bit Clock.
I ² S(1)_LRCLK*	83	81	I	I ² S (1) Left/Right Clock.
I ² S(1)_DATA*	81	79	I	I ² S (1) Serial Data Input.
SPORT_SDI*	100	98	I	Serial Port Digital Serial Input.
SPORT_SCLK*	97	95	O	Serial Port Serial Clock.
SPORT_SDFS*	98	96	O	Serial Port Serial Data Frame Synchronization.
SPORT_SDO*	99	97	O	Serial Port Serial Data Output.

Miscellaneous Analog Pins

Pin Name	PQFP	TQFP	I/O	Description
V _{REF_X}	36	34	O	Voltage Reference. Nominal 2.25 volt reference available for dc-coupling and level-shifting. V _{REF_X} should not be used to sink or source signal current. V _{REF_X} should be bypassed with 10 μ F and 0.1 μ F parallel capacitors.
V _{REF}	35	33	I	Voltage Reference Filter. Voltage reference filter point for external bypassing only. V _{REF} should be bypassed with 10 μ F and 0.1 μ F parallel capacitors.
L_FILT	38	36	I	Left Channel Filter. Requires a 1.0 μ F to analog ground for proper operation.
R_FILT	37	35	I	Right Channel Filter. Requires a 1.0 μ F to analog ground for proper operation.
L_AAFILT	40	38	I	Left Channel Antialias Filter. This pin requires a 560 pF NPO capacitor to analog ground for proper operation.
R_AAFILT	39	37	I	Right Channel Antialias Filter. This pin requires a 560 pF NPO capacitor to analog ground for proper operation.

Crystal Pin

Pin Name	PQFP	TQFP	I/O	Description
XTALO	64	62	O	33 MHz Crystal Output. If no Crystal is present leave XTALO unconnected.
XTALI	63	61	I	33 MHz Clock. When using a crystal as a clock source, the crystal should be connected between the XTALI and XTALO pins. Clock input may be driven into XTALI in place of a crystal. When using an external clock, V _{IH} must be 2.4 V rather than the V _{IH} of 2.0 V specified for all other digital inputs.

External Logical Devices

Pin Name	PQFP	TQFP	I/O	Description
LD_IRQ*	100	98	I	Logical Device IRQ.
LD_DACK*	99	97	O	Logical Device DACK.
LD_DRQ*	98	96	I	Logical Device DRQ.
$\overline{\text{LD_SEL}}$ *	97	95	O	Logical Device Select.
$\overline{\text{MDM_SEL}}$ *	83	81	O	Modem Chip Set Select.
$\overline{\text{MDM_IRQ}}$ *	82	82	I	Modem Chip Set IRQ.
$\overline{\text{LD_SEL1}}$ *	69	67	O	Logical Device (1) Select.
$\overline{\text{PNPRST}}$ *	68	66	O	Plug and Play Reset.

AD1816A

Hardware Volume Pins

Pin Name	PQFP	TQFP	I/O	Description
$\overline{\text{VOL_DN}}^*$	2, 99, 100	97, 98, 100	I	Master Volume Down. Modifies output level on pins L_OUT and R_OUT. When asserted LO, decreases Master Volume by 1.5 dB/sec. Must be asserted at least 25 ms to be recognized. When asserted simultaneously with $\overline{\text{VOL_UP}}$, output is muted. Output level modification reflected in indirect register [41].
$\overline{\text{VOL_UP}}^*$	1, 98	96, 99	I	Master Volume Up. Modifies output level on pins L_OUT and R_OUT. When asserted LO, increases Master Volume by 1.5 dB/sec. Must be asserted at least 25 ms to be recognized. When asserted simultaneously with $\overline{\text{VOL_UP}}$, output is muted. Output level modification reflected in indirect register [41].

Control Pins

Pin Name	PQFP	TQFP	I/O	Description
XCTL0*	68	66	O	External Control 0. The state of this pin (TTL HI or LO) is reflected in codec indexed register. This pin is an open drain driver.
PCLKO*	68	66	O	Programmable Clock Output. This pin can be programmed to generate an output clock equal to F_S , $8 \times F_S$, $16 \times F_S$, $32 \times F_S$, $64 \times F_S$, $128 \times F_S$ or $256 \times F_S$. MPEG decoders typically require a master clock of $256 \times F_S$ for audio synchronization.
XCTL1*	69	67	O	External Control 1. The state of this pin (TTL HI or LO) is reflected in codec indexed register. Open drain, 8 mA active 0.5 mA pull-up resistor.
RING*	69	67	I	Ring Indicator. Used to accept the ring indicator flag from the DAA.

Power Supplies

Pin Name	PQFP	TQFP	I/O	Description
V _{CC}	33	31	I	Analog Supply Voltage (+5 V).
G _{NDA}	34	32	I	Analog Ground.
V _{DD}	23, 62, 71, 89, 95	21, 60, 69, 87, 93	I	Digital Supply Voltage (+5 V).
G _{ND}	3*, 24, 65, 70, 84, 90, 96, 99*, 100*	1*, 22, 63, 68, 82, 88, 94, 97*, 98*	I	Digital Ground.

Optional EEPROM Pins

Pin Name	PQFP	TQFP	I/O	Description
EE_CLK	58	56	O	EEPROM Clock. Open drain output, requires external pull-up.
EE_DATA	57	55	I/O	EEPROM Data. Open drain I/O, requires external pull-up.

*The position of this pin location/function is dependent on the EEPROM data.

HOST INTERFACE

The AD1816A contains all necessary ISA bus interface logic on chip. This logic includes address decoding for all onboard resources, control and signal interpretation, DMA selection and control logic, IRQ selection and control logic, and all interface configuration logic.

The AD1816A supports a Type "F" DMA request/grant architecture for transferring data with the ISA bus through the 8-bit interface. The AD1816A also supports DACK preemption. Programmed I/O (PIO) mode is also supported for control register accesses and for applications lacking DMA control. The AD1816A includes dual DMA count registers for full-duplex operation enabling simultaneous capture and playback on separate DMA channels.

Codec Functional Description

The AD1816A's full-duplex stereo codec supports business audio and multimedia applications. The codec includes stereo audio converters, complete on-chip filtering, MPC Level-2 and Level-3 compliant analog mixing, programmable gain and attenuation, variable sample rate converters, extensive digital mixing and FIFOs buffering the Plug and Play ISA bus interface.

Analog Inputs

The codec contains a stereo pair of $\Sigma\Delta$ analog-to-digital converters (ADC). Inputs to the ADC can be selected from the following analog signals: mono (PHONE_IN), mono microphone (MIC), stereo line (LINE), external stereo synthesizer (SYNTH), stereo CD ROM (CD), stereo audio from a video source (VID) and post-mixed stereo or mono line output (OUT).

Analog Mixing

PHONE_IN, MIC, LINE, SYNTH, CD and VID can be mixed in the analog domain with the stereo line OUT from the $\Sigma\Delta$ digital-to-analog converters (DAC). Each channel of the stereo analog inputs can be independently gained or attenuated from +12 dB to -34.5 dB in 1.5 dB steps, except for PHONE_IN, which has a range of 0 dB to -45 dB steps. The summing path for the mono inputs (MIC, and PHONE_IN to line OUT) duplicates mono channel data on both the left and right line OUT, which can also be gained or attenuated from +12 dB to -34.5 dB in 1.5 dB steps for MIC, and +0 dB to -45.0 dB in 3 dB steps for PHONE_IN. The left and right mono summing signals are always identical being gained or attenuated equally.

Analog-to-Digital Datapath

The selector sends left and right channel information to the programmable gain amplifier (PGA). The PGA following the selector allows independent gain for each channel entering the ADC from 0 dB to 22.5 dB in 1.5 dB steps.

For supporting time correlated I/O echo cancellation, the ADC is capable of sampling microphone data on the left channel and the mono summation of left and right OUT on the right channel.

The codec can operate in either a global stereo mode or a global mono mode with left channel inputs appearing at both channels of the 16-bit $\Sigma\Delta$ converters. Data can be sampled at the programmed sampling frequency (from 4 kHz to 55.2 kHz with 1 Hz resolution).

Digital Mixing and Sample Rates

The audio ADC sample rate and the audio DAC sample rates are completely independent. The AD1816A includes a variable sample rate converter that lets the codec instantaneously change and process sample rates from 4 kHz to 55.2 kHz with a resolution of 1 Hz. The in-band integrated noise and distortion artifacts introduced by rate conversions are below -90 dB.

Up to four channels of digital data can be summed together and presented to the stereo DAC for conversion. Each digital channel pair can contain information encoded at a different sample rate. For example, 8 kHz .wav data received from the ISA interface, 48 kHz MPEG audio data received from I²S(0), digital 44.1 kHz CD data received from I²S(1) and internally generated 22.05 kHz music data may be summed together and converted by the DACs.

Digital-to-Analog Datapath

The internally generated music synthesizer data, PCM data received from the ISA interface, data received from the I²S(0) port and data received from the I²S(1) port, and the DSP serial port passes through an attenuation/mute stage. The attenuator allows independent control over each digital channel, which can be attenuated from 0 dB to -94.5 dB in 1.5 dB steps before being summed together and passed to the DAC, or the channel may be muted entirely.

Analog Outputs and Phat Stereo

The analog output of the DAC can be summed with any of the analog input signals. The summed analog signal enters the Master Volume stage where each channel L_OUT, R_OUT and PHONE_OUT may be attenuated from 0 dB to -46.5 dB in 1.5 dB steps or muted.

Analog Outputs and Phat Stereo

The AD1816A includes ADI's proprietary Phat Stereo 3D phase enhancement technology, which creates an increased sense of spaciousness using two speakers. Our unique patented feedback technology enables superior control over the width and depth of the acoustic signals arriving at the human ear. The AD1816A employs an electrical model of the speaker-to-ear path allowing precise control over a signal's phase at the ear. The Phat Stereo circuitry expands apparent sound images beyond the angle of the speakers by exploiting phase information in the audio signal and creating a more immersive listening experience.

Digital Data Types

The codec can process 16-bit twos complement PCM linear digital data, 8-bit unsigned magnitude PCM linear data and 8-bit μ -law or A-law companded digital data as specified in the control registers. The AD1816A also supports ADPCM encoded in the Creative SoundBlaster ADPCM formats.

Host-Based Echo Cancellation Support

The AD1816A supports time correlated I/O data format by presenting MIC data on the left channel of the ADC and the mono summation of left and right OUT on the right channel. The ADC sample rates are independent of the DAC sample rate allowing the AD1816A to support ADC time correlated I/O data at 8 kHz and DAC data at any other sample rate in the range of 4 kHz to 55.2 kHz simultaneously.

Telephony Support

The AD1816A contains a PHONE_IN input and a PHONE_OUT output. These pins are supplied so the AD1816A may be connected to a modem chip set, a telephone handset or down-line phone.

WSS and SoundBlaster Compatibility

Windows Sound System software audio compatibility is built into the AD1816A.

SoundBlaster emulation is provided through the SoundBlaster register set and the internal music synthesizer. SoundBlaster Pro version 3.02 functions are supported, including record and Creative SoundBlaster ADPCM.

AD1816A

Virtually all applications developed for SoundBlaster, Windows Sound System, AdLib and MIDI MPU-401 platforms run on the AD1816A SoundPort Controller. Follow the same development process for the controller as you would for these other devices.

As the AD1816A contains SoundBlaster (compatible) and Windows Sound System logical devices. You may find the following related development kits useful when developing AD1816A applications.

Developer Kit for SoundBlaster Series, 2nd ed. © 1993, Creative Labs, Inc., 1901 McCarthy Blvd., Milpitas, CA 95035
Microsoft Windows Sound System Driver Development Kit (CD), Version 2.0, © 1993, Microsoft Corp., One Microsoft Way, Redmond, WA 98052

The following reference texts can serve as additional sources of information on developing applications that run on the AD1816A.

S. De Furia & J. Scacciaferro, *The MIDI Implementation Book*, (© 1986, Third Earth, Pompton Lake)

C. Petzold, *Programming Windows: the Microsoft guide to writing applications for Windows 3.1*, 3rd. ed., (© 1992, Microsoft Press, Redmond)

K. Pohlmann, *Principles of Digital Audio*, (© 1989, Sams, Indianapolis)

A. Stolz, *The SoundBlaster Book*, (© 1993, Abacus, Grand Rapids)

J. Strawn, *Digital Audio Engineering, An Anthology*, (© 1985, Kaufmann, Los Altos)

Yamamoto, *MIDI Guidebook*, 4th. ed., (© 1987, 1989, Roland Corp.)

Multimedia PC Capabilities

The AD1816A is MPC-2 and MPC-3 compliant. This compliance is achieved through the AD1816A's flexible mixer and the embedded chip resources.

Music Synthesis

The AD1816A includes an embedded music synthesizer that emulates industry standard OPL3 FM synthesizer chips and delivers 20 voice polyphony. The internal synthesizer generates digital music data at 22.05 kHz and is summed into the DACs digital data stream prior to conversion. To sum synthesizer data with the ADC output, the ADC must be programmed for a 22.05 kHz sample rate.



The synthesizer is a hardware implementation of Eusynth-1+ code that was developed by Euphonics, a research and development company that specializes in audio processing and electronic music synthesis.

Wavetable MIDI Inputs

The AD1816A has a dedicated analog input for receiving an analog wavetable synthesizer output. Alternatively, a wavetable synthesizer's I²S formatted digital output can be directly connected to one of the AD1816A's I²S serial ports. Digital wavetable data from the AD1816A's I²S port may be summed with other digital data streams being handled by the AD1816A and then sent to the 16-bit $\Sigma\Delta$ DAC.

MIDI

The primary interface for communicating MIDI data to and from the host PC is the compatible MPU-401 interface that operates only in UART mode. The MPU-401 interface has two built-in FIFOs: a 64-byte receive FIFO and a 16-byte transmit FIFO.

Game Port

An IBM-compatible game port interface is provided on chip. The game port supports up to two joysticks via a 15-pin D-sub connector. Joystick registers supporting the Microsoft Direct Input standard are included as part of the codec register map. The AD1816A may be programmed to automatically sample the game port and save the value in the Joystick Position Data Register. When enabled, this feature saves up to 10% CPU MIPS by off-loading the host from constantly polling the joystick port.

Volume Control

The registers that control the Master Volume output stage are accessible through the ISA Bus. Master Volume output can also be controlled through a 2-pin hardware interface. One pin is used to increase the gain, the other pin attenuates the output and both pins together entirely mute the output. Once muted, any further activity on these pins will unmute the AD1816A's output.

Plug and Play Configuration

The AD1816A is fully Plug and Play configurable. For motherboard applications, the built-in Plug and Play protocol can be disabled with a software key providing a back door for the BIOS to configure the AD1816A's logical devices. For information on the Plug and Play mode configuration process, see the *Plug and Play ISA Specification Version 1.0a (May 5, 1994)*. All the AD1816A's logical devices comply with Plug and Play resource definitions described in the specification.

The AD1816A may alternatively be configured using an optional Plug and Play Resource ROM. When the EEPROM is present, some additional AD1816A muxed-pin features become available. For example, pins that control an external modem logical device are muxed with the DSP serial port. Some of these pin option combinations are mutually exclusive (see Appendix A for more information).

REFERENCES

The AD1816A also complies with the following related specifications; they can be used as an additional reference to AD1816A operations beyond the material in this data sheet.

Plug and Play ISA Specification, Version 1.0a, © 1993, 1994, Intel Corp. & Microsoft Corp., One Microsoft Way, Redmond, WA 98052

Multimedia PC Level 2 Specification, © 1993, Multimedia PC Marketing Council, 1730 M St. NW, Suite 707, Washington, DC 20036

MIDI 1.0 Detailed Specification & Standard MIDI Files 1.0, © 1994, MIDI Manufacturers Association, PO Box 3173 La Habra, CA 90632-3173

Recommendation G.711-Pulse Code Modulation (PCM) Of Voice Frequencies (μ -Law & A-Law Companding), The International Telegraph and Telephone Consultative Committee IX Plenary Assembly Blue Book, Volume III - Fascicle III.4, General Aspects Of Digital Transmission Systems; Terminal Equipment's, Recommendations G.700 - G.795, (Geneva, 1988), ISBN 92-61-03341-5

SERIAL INTERFACES

I²S Serial Ports

The two I²S serial ports on the AD1816A accept serial data in the following formats: Right-Justified, I²S-Justified and Left-Justified.

Figure 9 shows the right-justified mode. LRCLK is HI for the left channel and LO for the right channel. Data is valid on the rising edge of the BCLK. The MSB is delayed 16-bit clock periods from an LRCLK transition, so that when there are 64 BCLK periods per LRCLK period, the LSB of the data will be right-justified to the next LRCLK transition.

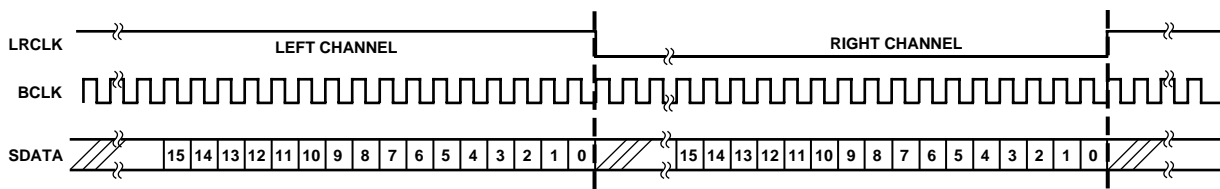

Figure 9. Serial Interface Right-Justified Mode

Figure 10 shows the I²S-justified mode. LRCLK is LO for the left channel and HI for the right channel. Data is valid on the rising edge of BCLK. The MSB is left-justified to an LRCLK transition, but with a single BCLK period delay.

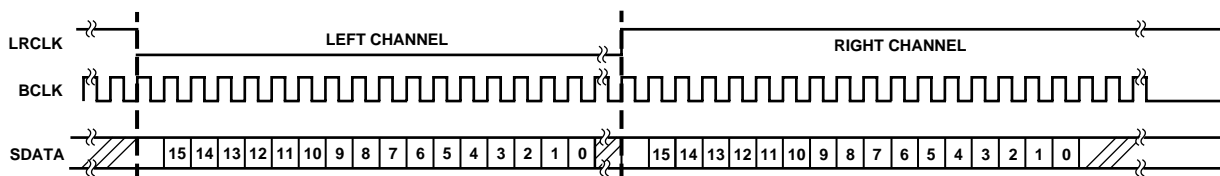

Figure 10. Serial Interface I²S-Justified Mode

Figure 11 shows the left-justified mode. LRCLK is HI for the left channel and LO for the right channel. Data is valid on the rising edge of BCLK. The MSB is left-justified to an LRCLK transition, with no MSB delay.

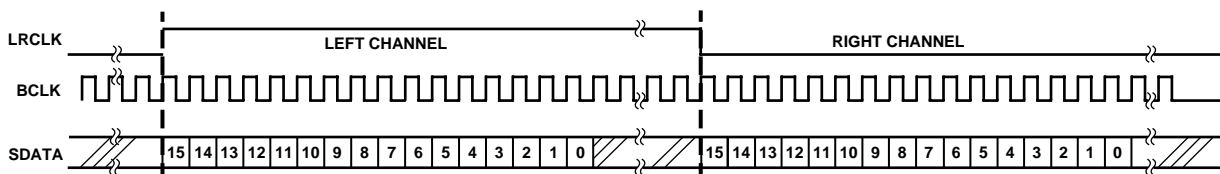

Figure 11. Serial Interface Left-Justified Mode

Bidirectional DSP Serial Interface

The AD1816A SoundPort Controller transmits and receives both data and control/status information through its DSP serial interface port (SPORT). The AD1816A is always the bus master and supplies the frame sync and the serial clock. The AD1816A has four pins assigned to the SPORT: SDI, SDO, SDFS and SCLK. The SPORT has two operating modes: monitor and intercept. The SPORT always monitors the various data streams being processed by the AD1816A. In intercept mode, any of the digital data streams can be manipulated by the DSP before reaching the final ADC or DAC stages.

The SDI and SDO pins handle the serial data input and output of the AD1816A. Communication in and out of the AD1816A requires that bits of data be transmitted after a rising edge of SCLK and sampled on the falling edge of SCLK. The SCLK frequency is always 11 MHz (or 1/3 or XTALI).

DSP Serial Port Interface time slots are mapped as shown in Table I.

Table I. DSP Port Time Slot Map

Time Slot	SDI Pin	SDO Pin
0	Control Word Input	Status Word Output
1	Control Register Data Input	Control Register Data Output
2	* SS/SB ADC Right Input (to ISA)	SS/SB ADC Right Output (from Codec)
3	* SS/SB ADC Left Input (to ISA)	SS/SB ADC Left Output (from Codec)
4	* SS/SB DAC Right Input (to Codec)	SS/SB DAC Right Output (from ISA)
5	* SS/SB DAC Left Input (to Codec)	SS/SB DAC Left Output (from ISA)
6	* FM DAC Right Input (to Codec)	FM DAC Right Output (from FM Synth Block)
7	* FM DAC Left Input (to Codec)	FM DAC Left Output (from FM Synth Block)
8	* I ² S (1) DAC Right Input (to Codec)	I ² S (1) DAC Right Output (from I ² S Port (1))
9	* I ² S (1) DAC Left Input (to Codec)	I ² S (1) DAC Left Output (from I ² S Port (1))
10	* I ² S (0) DAC Right Input (to Codec)	I ² S (0) DAC Right Output (from I ² S Port (0))
11	* I ² S (0) DAC Left Input (to Codec)	I ² S (0) DAC Left Output (from I ² S Port (0))

*This data is ignored by the AD1816A unless the channel pair is in intercept mode (see below).

SS = Sound System Mode
SB = SoundBlaster Mode

At start-up (after pin reset), there are exactly 12 time slots per frame. The frame rate will be 57,291 and 2/3 Hz (11 MHz sclk/ [16 bits × 12 slots]). Interfacing with an Analog Devices 21xx family DSP can be achieved by putting the ADSP-21xx in 24 slot per frame mode, where the first 12 and second 12 slots in the ADSP-21xx frame are identical.

The frame rate can be changed from its default by a write to the DFS(2:0) bits in register 33. Rate choices are: Maximum (57,291 and 2/3 Hz default), SS capture rate, SS playback rate, FM rate, I²S Port (1) rate, or I²S Port (0) rate. When the frame rate is less than 57,261 and 2/3 Hz, extra SCLK periods are added to fill up the time. The number of SCLK periods added will vary somewhat from frame to frame.

To control the sample data flow of each channel through the DSP Port, valid input, valid output and request bits are located in the control and status words. If the specified channel sample rate is equal to the frame rate, these bits may be ignored since they will always be set to "1."

By default, the DSP serial port allows only codec sample data I/O to be monitored. Intercept modes must be enabled to make substitutions in sample data flow to and from the codec. There are five bits in SS register 33, which enable intercept mode for SS capture, SS playback, FM playback, I²S Port (1) playback and I²S Port (0) playback.

Control Word Input (Slot 0 SDI)

15	14	13	12	11	10	9	8
FCLR	RES	RES	SSCVI	SSPVI	FMVI	IS1VI	IS0VI
7	6	5	4	3	2	1	0
ALIVE		R/W	IA[5:0]				

IA [5:0]	Indirect Register Address. Sound System Indirect Register Address defines the address of indirect registers shown in Table VI.
R/W	Read/Write request. Either a read from or a write to an SS indirect register occurs every frame. Setting this bit initiates an SS indirect register read while clearing this bit initiates an SS indirect register write.
ALIVE	DSP port alive bit. When set, this bit indicates to the power-down timer that the DSP port is active. When cleared, this bit indicates that the DSP port is inactive.
IS0VI	I ² S Port 0 Substitution Data Input Valid Flag. This bit is ignored if: (1) Intercept mode is not enabled for the I ² S port 0 channel pair, or (2) The AD1816A did not request data from the I ² S port 0 channel pair in the previous frame. Otherwise, setting this bit indicates that slots 10 and 11 contain valid right and left I ² S Port 0 substitution data. When this bit is cleared, data in slots 10 and 11 is ignored.
IS1VI	I ² S Port 1 Substitution Data Input Valid Flag. This bit is ignored if: (1) Intercept mode is not enabled for I ² S port 1 channel pair or (2) The AD1816A did not request data from the I ² S port channel pair in the previous frame. Otherwise, setting this bit indicates that Slots 8 and 9 contain valid right and left I ² S Port 1 substitution data. When this bit is cleared, data in slots 8 and 9 is ignored.
FMVI	FM Synthesis Substitution Data Input Valid Flag. This bit is ignored if: (1) Intercept mode is not enabled for the FM synthesis channel pair or (2) The AD1816A did not request data from the FM synthesis channel pair in the previous frame (see the FMRQ Bit 9 in the status word output). Otherwise, setting this bit to 1 indicates that slots 6 and 7 contain valid right and left FM synthesis channel substitution data. When this bit is reset to 0, data in slots 6 and 7 is ignored.

- SSPVI** SS/SB Playback Substitution Data Input Valid Flag. This bit is ignored if: (1) Intercept mode is not enabled for SS/SB playback or (2) The AD1816A did not request data for SS/SB playback in the previous frame (see the SSPRQ bit in the Status Word Output). Otherwise, setting this bit indicates that Slots 4 and 5 contain valid right and left SS/SB playback substitution data. If in “capture rate equal to playback rate” mode, setting this bit also indicates that valid capture substitution data is being sent to the AD1816A. If not in modem mode, right and left channel capture substitution data is accepted in Slots 2 and 3 respectively. If in modem mode, only mono capture substitution data is accepted in slots 2 and 3. When this bit is cleared, data in all slots controlled by this bit, as defined above, is ignored.
- SSCVI** SS/SB Capture Substitution Data Input Valid Flag. This bit is ignored if: (1) Intercept mode is not enabled for SS/SB capture or (2) The AD1816A did not request data for SS/SB capture in the previous frame (see the SSCRQ bit in the Status Word Output). Otherwise, setting this bit indicates that valid SS/SB capture substitution data is being sent to the AD1816A. If not in modem mode, or DSP port or ISA bus based, right and left channel capture data is accepted in Slots 2 and 3 respectively. If in modem mode, only mono capture substitution data is accepted in Slot 3, because Slot 2, which is mapped to the right capture channel, is being used for modem. This mono data will, however, be sent to both left and right ISA SS/SB capture channels. When this bit is cleared, data in Slots 3 and 2 is ignored.
- RES** Reserved: To ensure future compatibility write “0” to all reserved bits.
- FCLR** DSP Port Clear Status Flag. When this bit is set, (write 1), the PNPR and PDN flag bits in the status word (Bits 15 and 14 of slots 0 SDO) are cleared. When this bit is cleared, (writing a 0), it has no effect on PNPR and PDN and preserves them in the previous states.

Status Word Output (Slot 0 SDO)

15	14	13	12	11	10	9	8
PDN	PNPR	RES	SSCVO	SSPVO	FMVO	IS1VO	IS0VO
7	6	5	4	3	2	1	0
MB1	MB0	RES	SSCRQ	SSPRQ	FMRQ	IS1RQ	IS0RQ

- IS0RQ** I²S Port (0) Input Request Flag. This bit is set if intercept mode is enabled for I²S Port (0) and its four-word stereo input buffer is not full.
- IS1RQ** I²S Port (1) Input Request Flag. This bit is set if intercept mode is enabled for I²S Port (1) and its four-word stereo input buffer is not full.
- FMRQ** FM Synthesis Input Request Flag. This bit is set if intercept mode is enabled for FM synthesis and its four-word stereo input buffer is not full.
- SSPRQ** SS/SB Playback Input Request Flag. This bit is set if intercept mode is enabled for SS/SB playback and its four-word stereo input buffer is not full.
- SSCRQ** SS/SB Capture Input Request Flag. This bit is set if intercept mode is enabled for SS/SB capture and its four-word stereo input buffer is not full.
- MB0** Mailbox 0 Status Flag. This bit is set if the most recent action to SS indirect register 42 (DSP port Mail Box 1) was a write, and is cleared if the most recent action was a read. The status of this bit is also reflected in SS indirect register 33. It may be used as a handshake bit to facilitate communication between a DSP on the DSP port and a host CPU on the ISA bus.
- MB1** Mailbox 1 Status Flag. This bit is set if the most recent action to SS indirect register 43 (DSP port Mail Box 1) was a write and is cleared if the most recent action was a read. The status of this bit is also reflected in SS indirect register 33. It may be used as a handshake bit to facilitate communication between a DSP on the DSP port and a host CPU on the ISA bus.
- IS0VO** I²S Port 0 Valid Out. This bit is set if Slots 10 and 11 contain valid right and left I²S Port 0 data.
- IS1V1** I²S Port 1 Valid Out. This bit is set if Slots 8 and 9 contain valid right and left I²S Port 1 data.
- FMVO** FM Synthesis Valid Out. This bit is set if Slots 6 and 7 contain valid left and right FM synthesis data.
- SSPVO** SS/SB Playback Valid Out. This bit is set if Slots 4 and 5 contain valid right and left SS/SB playback data.
- SSCVO** SS/SB Capture Valid Out. This bit is set if valid SS/SB capture data is being transmitted. If not in a modem mode, Slots 2 and 3 will contain valid right and left SS/SB capture data. If in modem mode, only Slot 3 will contain valid left SS/SB capture data as Slot 2 and the ADC right channel are used by the modem.

AD1816A

PNPR Plug and Play Reset flag. This bit is set by an AD1816A reset (RESETB pin asserted LOW) or by a Plug and Play reset command. This bit is cleared by the assertion of the FCLR bit in the control word. While this bit is set, all attempts to write an SS indirect register via the DSP port will be ignored and fail. This is to ensure that Plug and Play resets are immediately applied to the application running on the DSP, without requiring them to continuously poll the Plug and Play reset status bit. During the frame in which this bit is cleared (by asserting FCLR), an attempt to write an SS indirect register will succeed. If the FCLR bit is continuously asserted, writes to indirect registers via the DSP port will always be enabled. A Plug and Play reset command will set this PNPR bit HIGH during at least one frame.

PDN Power-Down flag. This bit is set by an AD1816A reset (RESETB pin asserted LOW), or by an AD1816A power-down. Before an AD1816A power-down sequence shuts down the DSP port, at least one frame will be sent with this bit set. This bit can be cleared by the assertion of the FCLR (DSP port status clear) bit in the control word, providing the AD1816A is no longer in power-down.

The SDFS pin is used for the serial interface frame synchronization. New frames are marked by a one SCLK duration HI pulse, driven out on SDFS, one serial clock period before the frame begins. Upon initializing, there are exactly 12 time slots per frame and 16 bits per time slot. The frame rate is 57,291 and 2/3 Hz (11 MHz SCLK / (16 bits × 12 slots)). The frame rate can also be changed from the default value by reprogramming the rate in registers. The frame rate can run at the default rate or be programmed to match the modem sample rate, ADC capture rate, DAC playback rate, music sample rate, I²S(1) sample rate or I²S(0) sample rate. When the frame rate is not equivalent to the sample rate, Valid Out, Request In and Valid In bits are used to control the sample data flow. When the frame rate is equivalent to the sample rate, Valid and Request bits can be ignored.

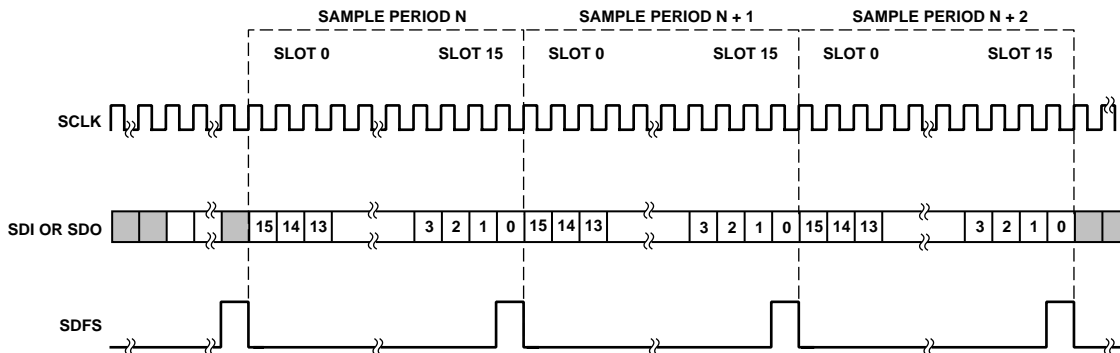

Figure 12. DSP Serial Interface (Default Frame Rate)

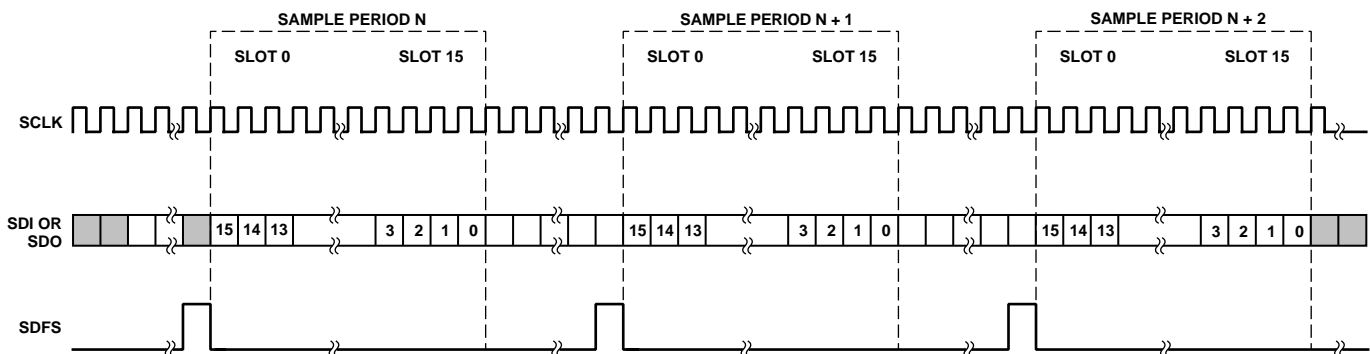

Figure 13. DSP Serial Interface (User Programmed Frame Rate)

Figure 14 illustrates the flexibility of the DSP Serial Port interface. This port can monitor or intercept any of the digital streams managed by the AD1816A. Any ADC or DAC data stream can be intercepted by the port, shipped to an external DSP or ASIC manipulated, and returned to any DAC summing path or to the ADC.

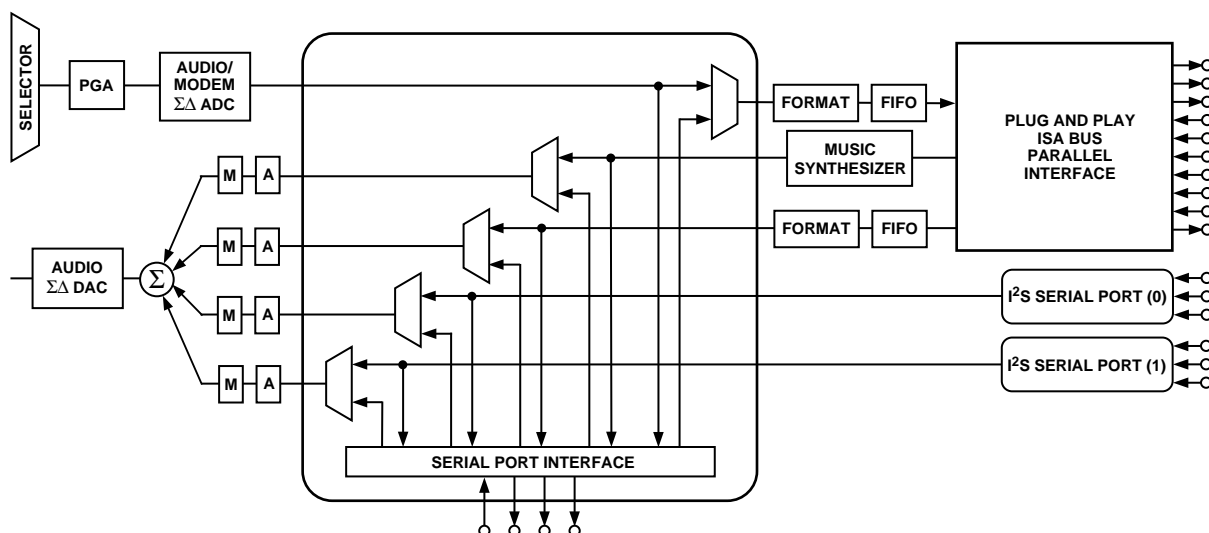

Figure 14. DSP Serial Port

ISA INTERFACE

AD1816A Chip Registers

Table II, Chip Register Diagram, details the AD1816A direct register set available from the ISA Bus. Prior to any accesses by the host, the PC I/O addressable ports must be configured using the Plug and Play Resources.

Table II. Chip Register Diagram

Register Type-Register Name	Register PC I/O Address
<i>Plug and Play</i> ADDRESS WRITE_DATA READ_DATA	0x279 0xA79 Relocatable in Range 0x203 - 0x3FF
<i>Sound System Codec</i> CODEC REGISTERS	0x(SS Base+0 - SS Base+15) Relocatable in Range 0x100 - 0x3FF See Table V
<i>SoundBlaster Pro</i> Music0: Address (w), Status (r) Music0: Data (w) Music1: Address (w) Music1: Data (w) Mixer Address (w) Mixer Data (w) Reset (w) Music0: Address (w) Music0: Data (w) Input Data (r) Status (r), Output Data (w) Status (r)	(SB Base) Relocatable in Range 0x100 - 0x3F0 (SB Base+1) (SB Base+2) (SB Base+3) (SB Base+4) (SB Base+5) (SB Base+6 or 7) (SB Base+8) (SB Base+9) (SB Base+A or +B) (SB Base+C or +D) (SB Base+E or +F)

AD1816A

Register Type-Register Name	Register PC I/O Address
<i>AdLib</i> Music0: Address (w), Status (r) Music0: Data (w) Music1: Address (w) Music1: Data (w)	(AdLib Base) Relocatable in Range 0x100 – 0x3F8 (AdLib Base+1) (AdLib Base+2) (AdLib Base+3)
<i>MIDI MPU-401</i> MIDI Data (r/w) MIDI Status (r), Command (w)	(MIDI Base) Relocatable in Range 0x100 – 0x3FE (MIDI Base+1)
<i>Game Port</i> Game Port I/O 0x100 – 0x3F8	(Game Base +0 to Game Base +7) Relocatable in Range

AD1816A Plug and Play Device Configuration Registers

The AD1816A may be configured according to the Intel/Microsoft Plug and Play Specification using the internal ROM. Alternatively, the PnP configuration sequence may be bypassed using the “Alternate Key Sequence” described in Appendix A.

The operating system configures the AD1816A Plug and Play Logical Devices after system boot. There are no “boot-devices” among the Plug and Play Logical Devices in the AD1816A. Non-Plug and Play BIOS systems configure the AD1816A’s Logical Devices after boot using drivers. Depending on BIOS implementations, Plug and Play BIOS systems may configure the AD1816A’s Logical Devices before POST or after Boot. See the *Plug and Play ISA Specification Version 1.0a* for more information on configuration control. To complete this configuration, the system reads resource data from the AD1816A’s on-chip resource ROM or optional EEPROM and from any other Plug and Play cards in the system, and then arbitrates the configuration of system resources with a heuristic algorithm. The algorithm maximizes the number of *active* devices and the *acceptability* of their configurations.

The system considers all Plug and Play logical device resource data at the same time and makes a conflict-free assignment of resources to the devices. If the system cannot assign a conflict-free resource to a device, the system does not configure or activate the device. All configured devices are activated.

The system’s Plug and Play support selects all necessary drivers, starts them and maintains a list of system resources allocated to each logical device. As an option, system resources can be reassigned at runtime with a Plug and Play Resource Manager. The custom setup created using the manager can be saved and used automatically on subsequent system boots.

Plug and Play Device IDs (embedded in the logical device’s resource data) provide the system with the information required to find and load the correct device drivers. One custom driver, the AD1816A Sound System driver from Analog Devices, is required for correct operation. In the other cases (MIDI, Game Port), the system can use generic drivers. Table III lists the AD1816A’s Logical Devices and compatible Plug and Play device drivers.

Table III. Logical Devices and Compatible Plug and Play Device Drivers

Logical Device Number	Emulated Device	Compatible (Device ID)	Device ID
0	Sound System	—	ADS7180
1	MIDI MPU401 Compatible	PNPB006	ADS7181
2	Game/Joystick Port	PNPB02F	ADS7182

The configuration process for the logical devices on the AD1816A is described in the *Plug and Play ISA Specification Version 1.0a (May 5, 1994)*. The specification describes how to transfer the logical devices from their start-up *Wait For Key* state to the *Config* state and how to assign I/O ranges, interrupt channels and DMA channels. See Appendix A for an example setup program and specific Plug and Play resource data.

Table IV describes in detail the I/O Port Address Descriptors, DMA Channels, Interrupts for the functions required for the AD1816A Logical Device groups.

Table IV. Internal Logical Device Configuration

LDN	PnP Function	Description
0	I/O Port Address Descriptor (0x60-0x61)	The SoundBlaster Pro address range is from 0x100 to 0x3F0. The typical address is 0x220. The range is 16 bytes long and must be aligned to a 16 byte memory boundary.
0	I/O Port Address Descriptor (0x62-0x63)	The AdLib address range is from 0x100 to 0x3F8. The typical address is 0x388. The range is 4 bytes long and must be aligned to an 8 byte memory boundary.
0	I/O Port Address Descriptor (0x64-0x65)	The Codec address range is from 0x100 to 0x3F8. The range is 16 bytes long and must be aligned to a 16 byte memory boundary.
0	Interrupt Request Level Select (0x70-0x71)	This IRQ is shared between the SB Pro device and the Codec. These devices require one of the following IRQ channels: 5, 7, 9, 11, 12 or 15. Typically, the IRQ is set to 5 or 7 for this device.
0	DMA Playback Channel Select (0x74)	This 8-bit channel is shared between the SB Pro device and the Codec for playback. These devices require one of the following DMA channels: 0, 1, 3. Typically, DMA channel 1 is set.
0	DMA Capture Channel Select (0x75)	This the DMA channel used for capturing Codec data. The Codec operates in single channel mode if a separate DMA channel for capture and playback is not assigned. The following DMA channels may be programmed: 0, 1, 3. DMA Channel 4 indicates single channel mode.
1	I/O Port Address Descriptor (0x60-0x61)	The MPU-401 compatible device address range is 0x100 to 0x3FE. Typical configurations use 0x330. The range is 2 bytes long and must be aligned to a 2 byte memory boundary.
1	Interrupt Request Level Select (0x70-0x71)	The MIDI device requires one of the following IRQ channels: 5, 7, 9, 11, 12 or 15.
2	I/O Port Address Descriptor (0x60-0x61)	The Game Port address range is from 0x100 to 0x3F8. The typical address is 0x200. The range is 8 bytes long and must be aligned to an 8 byte memory boundary.

NOTE

DMA channel 4 indicates single-channel mode.

Sound System Direct Registers

The AD1816A has a set of 16 programmable Sound System Direct Registers and 36 Indirect Registers. This section describes all the AD1816A registers and gives their address, name and initialization state/reset value. Following each register table is a list (in ascending order) of the full register name, its usage and its type: (RO) Read Only, (WO) Write Only, (STKY) Sticky, (RW) Read Write and Reserved (res). Table V is a map of the AD1816A direct registers.

Table V. Sound System Direct Registers

Direct Address	Bit 7	Bit 6	Bit 5	Bit 4	Bit 3	Bit 2	Bit 1	Bit 0
SSBASE + 0	CRDY	VBL	INADR[5:0]					
SSBASE + 1	PI	CI	TI	VI	DI	RI	GI	SI
SSBASE + 2	Indirect SS Data [7:0]							
SSBASE + 3	Indirect SS Data [15:8]							
SSBASE + 4	RES		PUR	COR	ORR [1:0]		ORL [1:0]	
SSBASE + 5	PFH	PDR	PLR	PUL	CFH	CDR	CLR	CUL
SSBASE + 6	PIO Playback/Capture [7:0]							
SSBASE + 7	RESERVED							
SSBASE + 8	TRD	DAZ	PFMT [1:0]		PC/L	PST	PIO	PEN
SSBASE + 9	RES		CFMT [1:0]		CC/L	CST	CIO	CEN
SSBASE + 10	RESERVED							
SSBASE + 11	RESERVED							
SSBASE + 12	JOYSTICK DATA [7:0]							
SSBASE + 13	JRDY	JWRP	JSEL [1:0]		JMSK [3:0]			
SSBASE + 14	JAXIS [7:0]							
SSBASE + 15	JAXIS [15:8]							

AD1816A

[Base+0] Chip Status/Indirect Address

7	6	5	4	3	2	1	0		
CRDY	VBL	INADR[5:0]							RESET = [0x00]

INADR [5:0] (RW) Indirect Address for Sound System (SS). These bits are used to access the Indirect Registers shown in Table VIII. All registers data must be written in pairs, low byte followed by high byte, by loading the Indirect SS Data Registers, (Base +2) and (Base +3).

VBL Volume Button Location. When using an EEPROM to configure the PnP state of the AD1816A, this bit determines whether PQFP Pins 1 and 2 (TQFP Pins 99 and 100) are used for $\overline{\text{VOL_UP}}$ and $\overline{\text{VOL_DN}}$ or I²S0_DATA and I²S0_LRCLK respectively.

0 I²S0_DATA and I²S0_LRCLK
 1 $\overline{\text{VOL_UP}}$ and $\overline{\text{VOL_DN}}$

CRDY (RO) AD1816A Ready. The AD1816A asserts this bit when AD1816A can accept data.

0 AD1816A not ready
 1 AD1816A ready

[Base+1] Interrupt Status

7	6	5	4	3	2	1	0	
PI	CI	TI	VI	DI	RI	GI	SI	RESET = [0x00]

SI (RO) SoundBlaster generated Interrupt.

0 No interrupt
 1 SoundBlaster interrupt pending

GI (RW) Game Interrupt (Sticky, Write "0" to Clear).

0 No interrupt
 1 An interrupt is pending due to Digital Game Port data ready

RI (RW) Ring Interrupt (Sticky, Write "0" to Clear).

0 No interrupt
 1 An interrupt is pending due to a Hardware Ring pin being asserted

DI (RW) DSP Interrupt (Sticky, Write "0" to Clear).

0 No interrupt
 1 An interrupt is pending due to a write to the DIT bit in indirect register [33] bit <13>

VI (RW) Volume Interrupt (Sticky, Write "0" to Clear).

0 No interrupt
 1 An interrupt is pending due to Hardware Volume Button being pressed

TI (RW) Timer Interrupt. This bit indicates there is an interrupt pending from the timer count registers. (Sticky, Write "0" to Clear).

0 No interrupt
 1 Interrupt is pending from the timer count register

CI (RW) Capture Interrupt. This bit indicates that there is an interrupt pending from the capture DMA count register. (Sticky, Write "0" to Clear).

0 No interrupt
 1 Interrupt is pending from the capture DMA count register

PI (RW) Playback Interrupt. This bit indicates that there is an interrupt pending from the playback DMA count register. (Sticky, Write "0" to Clear).

0 No interrupt
 1 Interrupt is pending from the playback DMA count register

[Base+2] Indirect SS Data Low Byte

7	6	5	4	3	2	1	0	
Indirect SS Data [7:0]								RESET = [0xXX]

[Base+3] Indirect SS Data High Byte

7	6	5	4	3	2	1	0	
Indirect SS Data [15:8]								RESET = [0xXX]

Indirect SS Data [15:0] Indirect Sound System Data. Data in this register is written to the Sound System Indirect Register specified by the address contained in INADR [5:0], Sound System Direct Register [Base +0]. Data is written when the Indirect SS Data High Byte value is loaded.

[Base+4] PIO Debug

7	6	5	4	3	2	1	0	
RES	PUR	COR	ORR[1:0]	ORR[1:0]				RESET = [0x00]

All bits in this register are sticky until any write that clears all bits to 0.

ORL/ORR (RO) [1:0] Overrange Left/Right detect. These bits record the largest output magnitude on the ADC right and left channels and are cleared to 00 after any write to this register. The peak amplitude as recorded by these bits is “sticky,” i.e., the largest output magnitude recorded by these bits will persist until these bits are explicitly cleared. They are also cleared by powering down the chip.

ORL/ORR	Over/Under Range Detection
00	Less than -1 dB Underrange
01	Between -1 dB and 0 dB Underrange
10	Between 0 dB and 1 dB Overrange
11	Greater than 1 dB Overrange

COR (RO) Capture Over Run. The codec sets (1) this bit when capture data is not read within one sample period after the capture FIFO fills. When COR is set, the FIFO is full and the codec discards any new data generated. The codec clears this bit immediately after a 4 byte capture sample is read.

PUR (RO) Playback Under Run. The codec sets (1) this bit when playback data is not written within one sample period after the playback FIFO empties. The codec clears (0) this bit immediately after a 4 byte playback sample is written. When PUR is set, the playback channel has “run out” of data and either plays back a midscale value or repeats the last sample.

[Base+5] PIO Status

7	6	5	4	3	2	1	0	
PFH	PDR	PLR	PUL	CFH	CDR	CLR	CUL	RESET = [0x00]

CUL (RO) Capture Upper/Lower Sample. This bit indicates whether the PIO capture data ready is for the upper or lower byte of the channel.
 0 Lower byte ready
 1 Upper byte ready or any 8-bit mode

CLR (RO) Capture Left/Right Sample. This bit indicates whether the PIO capture data waiting is for the left channel ADC or the right channel ADC.
 0 Right channel
 1 Left channel or mono

CDR (RO) Capture Data Ready. The PIO Capture Data register contains data ready for reading by the host. This bit should be used only when direct programmed I/O data transfers are desired (FIFO has at least 4 bytes before full).
 0 ADC is stale. Do not reread the information
 1 ADC data is fresh. Ready for next host data read

CFH (RO) Capture FIFO Half Full. (FIFO has at least 32 bytes before full.)

PUL (RO) Playback Upper/Lower Sample. This bit indicates whether the PIO playback data needed is for the upper or lower byte of the channel.
 0 Lower byte needed
 1 Upper byte needed or any 8-bit mode

PLR (RO) Playback Left/Right Sample. This bit indicates whether the PIO playback data needed is or the left channel DAC or the right channel DAC.
 0 Right channel needed
 1 Left channel or mono

PDR (RO) Playback Data Ready. The PIO Playback data register is ready for more data. This bit should only be used when direct programmed I/O data transfers are desired (FIFO can take at least 4 bytes).
 0 DAC data is still valid. Do not overwrite
 1 DAC data is stale. Ready for next host data write value

PFH (RO) Playback FIFO Half Empty. FIFO can take at least 32 bytes, eight groups of 4 bytes.

AD1816A

[Base+6] PIO Data

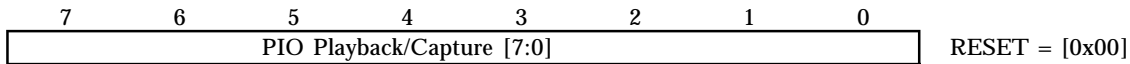

PIO Playback/ Capture [7:0]

The Programmed I/O (PIO) Data Registers for capture and playback are mapped to the same address. Writes send data to the Playback Register and reads will receive data from the Capture Register.

Reading this register will increment the capture byte state machine so that the following read will be from the next appropriate byte in the sample. The exact byte may be determined by reading the PIO Status Register. Once all relevant bytes have been read, the state machine will stay pointed to the last byte of the sample until a new sample is received.

Writing data to this register will increment the playback byte tracking state machine so that the following write will be to the correct byte of the sample. Once all bytes have been written, subsequent byte writes will be ignored. The state machine is reset when the current sample is transferred.

Note: All writes to the FIFO “MUST” contain 4 bytes of data.

- * 1 sample of 16-bit stereo
- * 2 samples of 16-bit mono
- * 2 samples of 8-bit stereo (Linear PCM, μ -law PCM, A-Law PCM)
- * 4 samples of 8-bit mono (Linear PCM, μ -law PCM, A-Law PCM)

[Base+7] Reserved

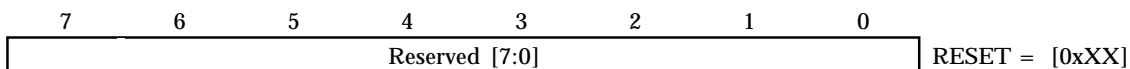

[Base+8] Playback Configuration

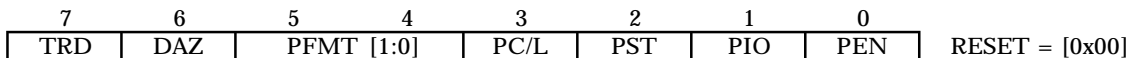

- | | | |
|------------|------|--|
| PEN | (RW) | Playback Enable. This bit enables or disables programmed I/O data playback.
0 Disable
1 Enable |
| PIO | (RW) | Programmed Input/Output. This bit determines whether the playback data is transferred via DMA or PIO.
0 DMA transfers only
1 PIO transfers only |
| PST | (RW) | Playback Stereo/Mono select. These bits select stereo or mono formatting for the input audio data streams. In stereo, the Codec alternates samples between channels to provide left and right channel input. For mono, the Codec captures samples on the left channel stereo.
0 Mono
1 Stereo |
| PC/L | (RW) | Playback Companded/Linear Select. This bit selects between a linear digital representation of the audio signal or a nonlinear companded format for all output data. The type of linear PCM or the type of companded format is defined by PFMT [1:0].
0 Linear PCM
1 Companded |
| PFMT [1:0] | (RW) | Playback Format. Use these bits to select the playback data format for output data according to Table VI and Figure 15. |
| DAZ | (RW) | DAC zero. This bit forces the DAC to zero.
0 Repeat last sample
1 Force DAC to ZERO |
| TRD | (RW) | Transfer Request Disable. This bit enables or disables Codec DMA transfers during a Codec interrupt (indicated by the SS Codec Status register’s INT bit being set [1]). This assumes Codec DMA transfers were enabled and the PEN or CEN bits are set.
0 Transfer Request Enable
1 Transfer Request Disable |

After setting format bits, sample data into the AD1816A must be ordered according to Figure 15, Table VI.

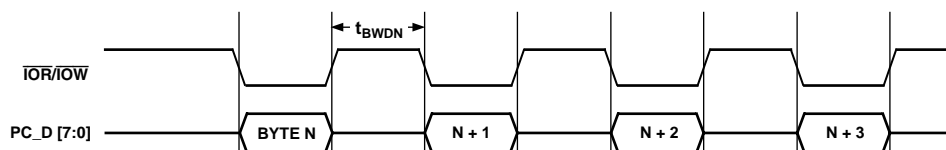

Figure 15. Codec Transfers

Table VI. Codec Transfers

ST	FMT1 FMT0 C/L	Format	Byte 3		Byte 2		Byte 1		Byte 0	
			MSB	LSB	MSB	LSB	MSB	LSB	MSB	LSB
0	000	Mono Linear, 8-Bit Unsigned	Sample 3 8 Bits Left Channel	Sample 2 8 Bits Left Channel	Sample 1 8 Bits Left Channel	Sample 0 8 Bits Left Channel				
1	000	Stereo Linear, 8-Bit Unsigned	Sample 1 8 Bits Right Channel	Sample 1 8 Bits Left Channel	Sample 0 8 Bits Right Channel	Sample 0 8 Bits Left Channel				
0	001	Mono μ -Law, 8-Bit Companded	Sample 3 8 Bits Left Channel	Sample 2 8 Bits Left Channel	Sample 1 8 Bits Left Channel	Sample 0 8 Bits Left Channel				
1	001	Stereo μ -Law, 8-Bit Companded	Sample 1 8 Bits Right Channel	Sample 1 8 Bits Left Channel	Sample 0 8 Bits Right Channel	Sample 0 8 Bits Left Channel				
0	010	Mono Linear 16-Bit Little Endian	Sample 1 Upper 8 Bits Left Channel	Sample 1 Lower 8 Bits Left Channel	Sample 0 Upper 8 Bits Left Channel	Sample 0 Lower 8 Bits Left Channel				
1	010	Stereo Linear 16-Bit Little Endian	Sample 0 Upper 8 Bits Right Channel	Sample 0 Lower 8 Bits Right Channel	Sample 0 Upper 8 Bits Left Channel	Sample 0 Lower 8 Bits Left Channel				
0	011	Mono A-Law, 8-Bit Companded	Sample 3 8 Bits Left Channel	Sample 2 8 Bits Left Channel	Sample 1 8 Bits Left Channel	Sample 0 8 Bits Left Channel				
1	011	Stereo A-Law, 8-Bit Companded	Sample 1 8 Bits Right Channel	Sample 1 8 Bits Left Channel	Sample 0 8 Bits Right Channel	Sample 0 8 Bits Left Channel				
0	100	Reserved								
1	100	Reserved								
0	101	Reserved								
1	101	Reserved								
0	110	Mono Linear, 16-Bit Big Endian	Sample 1 Lower 8 Bits Left Channel	Sample 1 Upper 8 Bits Left Channel	Sample 0 Lower 8 Bits Left Channel	Sample 0 Upper 8 Bits Left Channel				
0	110	Stereo Linear, 16-Bit Big Endian	Sample 0 Lower 8 Bits Right Channel	Sample 0 Upper 8 Bits Left Channel	Sample 0 Lower 8 Bits Left Channel	Sample 0 Upper 8 Bits Left Channel				
0	111	Reserved								
1	111	Reserved								

AD1816A

[Base+9] Capture Configuration

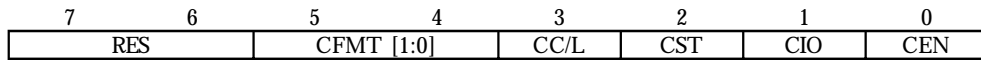

RESET = [0x00]

CEN (RW) Capture Enable. This bit enables or disables data capture.
 0 Disable
 1 Enable

CIO (RW) Capture Programmed I/O. This bit determines whether the capture data is transferred via DMA or PIO.
 0 DMA
 1 PIO

CST (RW) Capture Stereo/Mono Select. This bit selects stereo or mono formatting for the input audio data streams. In stereo, the Codec alternates samples between channels to provide left and right channel input. For mono, the Codec captures samples on the left channel.
 0 Mono
 1 Stereo

CC/L (RW) Capture Companded/Linear Select. This bit selects between a linear digital representation of the audio signal or a nonlinear, companded format for all output data. The type of linear PCM or the type of companded format is defined by CFMT [1:0].
 0 Linear PCM
 1 Companded

CFMT [1:0] (RW) Capture Format. Use these bits to select the format for capture data according to the following Table VI and Figure 15.

[Base+10] Reserved



RESET = [0xXX]

[Base+11] Reserved



RESET = [0xXX]

[Base+12] Joystick RAW DATA

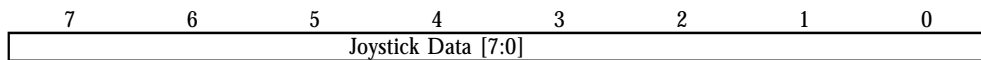

RESET = [0xF0]

Joystick Data (RO) Joystick Data. Joystick Data (identical to LDN 2): Writes to this register are ignored.

[Base+13] Joystick Control

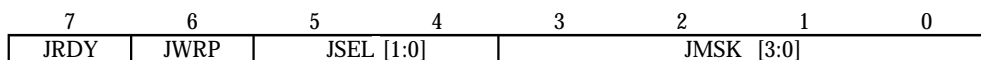

RESET = [0xF0]

JMSK [3:0] (RW) Joystick Axis Mask. JRDY bit calculated based on axes selected by JMSK only.

xxx1	Enable AX
xx1x	Enable AY
x1xx	Enable BX
1xxx	Enable BY

JSEL [1:0] (RW) Joystick Select. Selects one of four joystick axis register sets according to the following table:

00	Read AX (16 Bits) from [Base+14] & [Base+15]
01	Read AY (16 Bits) from [Base+14] & [Base+15]
10	Read BX (16 Bits) from [Base+14] & [Base+15]
11	Read BY (16 Bits) from [Base+14] & [Base+15]

JWRP (RW) Joystick Wrapmode. Continuous Joystick sampling mode—sampling automatically restarted every ~16 ms.

JRDY (RO) Joystick Ready. Sampling complete, joystick data ready for reading.

Note: Sampling must be started manually if JWRP is set before any sampling cycles are run. To start sampling after setting the JWRP bit, write to the joystick port [Base+14].

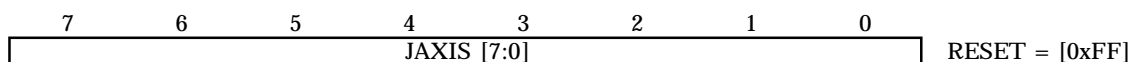
[Base+14] Joystick Position Data Low Byte

JAXIS [7:0] (RO) Joystick Axis Low Byte.

Note: Axis to be read through this register is selected by the JSEL bits in the control register. A write to this register starts a sampling cycle.

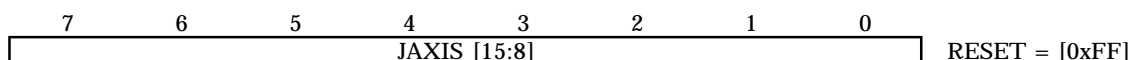
[Base+15] Joystick Position Data High Byte

JAXIS [15:8] (RO) Joystick Axis High Byte.

Note: Axis to be read through this register is selected by the JSEL bits in the control register. A write to this register starts a sampling cycle

Sound System Indirect Registers***Writing Indirect Registers***

All Indirect Registers must be written in pairs: low byte followed by high byte. The Indirect Address Register [SSBASE+0] holds the address for a register pair, the Indirect Low Data Byte [SSBASE+2] is used to write low data byte and the Indirect High Data Byte [SSBASE+3] is used to write the high data byte. The low data byte is held in the temporary register until the upper byte is written.

Programming Example

“Write Sample Rate for Voice Playback at 11,000 Hz (0x2AF8)”

- 1) Write [SSBASE+0] with 0x02 ; indirect register for voice playback sample rate
- 2) Write [SSBASE+2] with 0xF8 ; low byte of 16-bit sample rate register
- 3) Write [SSBASE+3] with 0x2A ; high byte of 16-bit sample rate register

Reading Indirect Registers

All indirect registers can be individually read. The Sound System Indirect Address Register [SSBASE+0] holds the address for a register pair, the Indirect Low Data Byte [SSBASE+2] is used to read low data byte and Indirect High Data Byte [SSBASE+3] is used to read the High data byte.

Programming Example

“Read Sample Rate for Voice Playback set to 11,000 Hz (0x2AF8)”

- 1) Write [SSBASE+0] with 0x02 ; indirect register for voice playback sample rate
- 2) Read [SSBASE+2] ; low byte of 16-bit sample rate register set to 0xF8
- 3) Read [SSBASE+3] ; high byte of 16-bit sample rate register set to 0x2A

ISR Saves and Restores

For Interrupt Service Routines, ISRs, it is necessary to save and restore the Indirect Address and the Low Byte Temporary Data holding registers inside the ISR.

Programming Example

“Save/Restore during an ISR”

Beginning of ISR:

- 1) Read [SSBASE+0] ; save Indirect Address register to TMP_IA
- 2) Write [SSBASE+0] with 0x00; ; indirect Register for Low Byte Temporary Data
- 3) Read [SSBASE+2] ; save Low Byte Temporary data to TMP_LBT
- 4) ISR Code ; ISR routine
- 5) Write [SSBASE+2] with TMP_LBT ; restore Low Byte Temporary data TMP_LBT
- 6) Write [SSBASE+0] with TMP_IA ; restore Indirect Address Register to TMP_IA
- 7) Return from Interrupt ; return from ISR

Table VII. Indirect Register Map and Reset/Default States

Address	Register Name	Reset/ Default State
00	Low Byte TMP	0xXX
01	Interrupt Enable and External Control	0x0102
02	Voice Playback Sample Rate	0x1F40
03	Voice Capture Sample Rate	0x1F40
04	Voice Attenuation	0x8080
05	FM Attenuation	0x8080
06	I ² S(1) Attenuation	0x8080
07	I ² S(0) Attenuation	0x8080
08	Playback Base Count	0x0000
09	Playback Current Count	0x0000
10	Capture Base Count	0x0000
11	Capture Current Count	0x0000
12	Timer Base Count	0x0000
13	Timer Current Count	0x0000
14	Master Volume Attenuation	0x0000
15	CD Gain/Attenuation	0x8888
16	Synth Gain/Attenuation	0x8888
17	Video Gain/Attenuation	0x8888
18	Line Gain/Attenuation	0x8888
19	Mic/PHONE_IN Gain/Attenuation	0x8888
20	ADC Source Select and ADC PGA	0x0000
32	Chip Configuration	0x00F0
33	DSP Configuration	0x0000
34	FM Sample Rate	0x5622
35	I ² S(1) Sample Rate	0xAC44
36	I ² S(0) Sample Rate	0xAC44
37	Reserved	0x0000
38	Programmable Clock Rate	0xAC44
39	3D Phat Stereo Control/PHONE_OUT Gain Attenuation	0x8000
40	Reserved	0x0000
41	Hardware Volume Button Modifier	0xFF1B
42	DSP Mailbox 0	0x0000
43	DSP Mailbox 1	0x0000
44	Power-Down and Timer Control	0x0000
45	Version ID	0XXXXX
46	Reserved	0x0000

Table VIII. Sound System Indirect Registers

ADDRESS	(High Byte)								(Low Byte)									
	7	6	5	4	3	2	1	0	7	6	5	4	3	2	1	0		
00 (0x00)	RES								LBTD [7:0]									
01 (0x01)	PIE	CIE	TIE	VIE	DIE	RIE	JIE	SIE	TE								XC1	XC0
02 (0x02)	VPSR [15:8]								VPSR [7:0]									
03 (0x03)	VCSR [15:8]								VCSR [7:0]									
04 (0x04)	LVM	RES	LVA [5:0]				RVM	RES	RVA [5:0]									
05 (0x05)	LFMM	RES	LFMA [5:0]				RFMM	RES	RFMA [5:0]									
06 (0x06)	LS1M	RES	LS1A [5:0]				RS1M	RES	RS1A [5:0]									
07 (0x07)	LS0M	RES	LS0A [5:0]				RS0M	RES	RS0A [5:0]									
08 (0x08)	PBC [15:8]								PBC [7:0]									
09 (0x09)	PCC [15:8]								PCC [7:0]									
10 (0x0A)	CBC [15:8]								CBC [7:0]									
11 (0x0B)	CCC [15:8]								CCC [7:0]									
12 (0x0C)	TBC [15:8]								TBC [7:0]									
13 (0x0D)	TCC [15:8]								TCC [7:0]									
14 (0x0E)	LMVM	RES	LMVA [4:0]				RMVM	RES	RMVA [4:0]									
15 (0x0F)	LCDM	RES	LCDA [4:0]				RCDM	RES	RCDA [4:0]									
16 (0x10)	LSYM	RES	LSYA [4:0]				RSYM	RES	RSYA [4:0]									
17 (0x11)	LVDM	RES	LVDA [4:0]				RVDM	RES	RVDA [4:0]									
18 (0x12)	LLM	RES	LLA [4:0]				RLM	RES	RLA [4:0]									
19 (0x13)	MCM	M20	RES	MCA [4:0]				PIM	RES	PIA [3:0]				RES				
20 (0x14)	LAGC	LAS [2:0]		LAG [3:0]			RAGC	RAS [2:0]		RAG [3:0]								
32 (0x20)	WSE	CDE	RES	CNP	RES			COF [3:0]			I2SF1 [1:0]	I2SF0 [1:0]						
33 (0x21)	DS1	DS0	DIT	RES		ADR	I1T	I0T	CPI	PBI	FMI	I1I	I0I	DFS [2:0]				
34 (0x22)	FSMR [15:8]								FSMR [7:0]									
35 (0x23)	S1SR [15:8]								S1SR [7:0]									
36 (0x24)	S0SR [15:8]								S0SR [7:0]									
37 (0x25)	RES								RES									
38 (0x26)	PCR [15:8]								PCR [7:0]									
39 (0x27)	3DDM	RES	3DD [3:0]		RES	POM	RES	POA [4:0]										
40 (0x28)	RES								RES									
41 (0x29)	RES								VMU	VUP	VDN	BM [4:0]						
42 (0x2A)	MB0R [15:8]								MB0R [7:0]									
43 (0x2B)	MB1R [15:8]								MB1R [7:0]									
44 (0x2C)	CPD	RES	PIW	PIR	PAA	PDA	PDP	PTB	3D	PD3D	GPSP	RES	DM	RES				
45 (0x2D)	VER [15:8]								VER [7:0]									
46 (0x2E)	RES								RES									

[00] INDIRECT LOW BYTE TMP**DEFAULT = [0xXX]**

7	6	5	4	3	2	1	0	7	6	5	4	3	2	1	0
RES								LBTD [7:0]							

LBTD [7:0] Low Byte Temporary Data holding latch for register pair writes;

Written on any write to [SSBase + 2].

Read from [SSBase + 2] when the indirect address is 0x00.

[01] INTERRUPT ENABLE AND EXTERNAL CONTROL**DEFAULT = [0x0102]**

7	6	5	4	3	2	1	0	7	6	5	4	3	2	1	0		
PIE	CIE	TIE	VIE	DIE	RIE	JIE	SIE	TE	RES							XC1	XC0

XC0	RW	External Control 0. The state of this bit is reflected on the XCTL0 pin. This pin is also muxed with PCLKO. COF must be greater than 0x1011 for PCLKO to be disabled, see SS [32].
XC1	RW	External Control 1. The state of this bit is reflected on the XCTL1 pin. XCTL1 may also be used for Ring-In Interrupt. Open drain output, contains internal pull-up ~ 0.5 mA.
TE	RW	Timer Enable Bit.
SIE	RW	SoundBlaster Interrupt Enable; This bit must be set to enable Current Count Timer. 0 SoundBlaster Interrupt disabled 1 SoundBlaster Interrupt enabled
JIE	RW	Joystick Interrupt Enable; 0 Joystick Interrupt disabled 1 Joystick Interrupt enabled

AD1816A

RIE	RW	Ring Interrupt Enable; 0 Ring Interrupt disabled 1 Ring Interrupt enabled
DIE	RW	DSP Interrupt Enable; 0 DSP Interrupt disabled 1 DSP Interrupt enabled
VIE	RW	Volume Interrupt Enable. If enabled, software increments/decrements BUTTON MODIFIER via interrupt routine and pushing buttons only sets VUP, VDN, VMU bits. It does not change the volume. 0 Volume Interrupt disabled 1 Volume Interrupt enabled
TIE	RW	Timer Interrupt Enable; 0 Timer Interrupt disabled 1 Timer Interrupt enabled
CIE	RW	Capture Interrupt Enable; 0 Capture Interrupt disabled 1 Capture Interrupt enabled
PIE	RW	Playback Interrupt Enable; 0 Playback Interrupt disabled 1 Playback Interrupt enabled

[02] VOICE PLAYBACK SAMPLE RATE **DEFAULT = [0x1F40]**

7	6	5	4	3	2	1	0	7	6	5	4	3	2	1
VPSR [15:8]								VPSR [7:0]						

VPSR [15:0] Voice Playback Sample Rate. The sample rate can be programmed from 4 kHz to 55.2 kHz in 1 hertz increments. The default playback sample rate is 8 kHz.

[03] VOICE CAPTURE SAMPLE RATE **DEFAULT = [0x1F40]**

7	6	5	4	3	2	1	0	7	6	5	4	3	2	1	0
VCSR [15:8]								VCSR [7:0]							

VCSR [15:0] Voice Capture Sample Rate. The sample rate can be programmed from 4 kHz to 55.2 kHz in 1 hertz increments. Ignored if CNP bit in SS [32] = 0 in which case VPSR [15:0] controls capture rate. The default capture sample rate is 8 kHz.

[04] VOICE ATTENUATION **DEFAULT = [0x8080]**

7	6	5	4	3	2	1	0	7	6	5	4	3	2	1	0
LVM	RES	LVA [5:0]						RVM	RES	RVA [5:0]					

RVA [5:0] Right Voice Attenuation for Playback channel. The LSB represents -1.5 dB, 000000 = 0 dB and the range is 0 dB to -94.5 dB.

RVM Right Voice Mute. 0 = Unmuted, 1 = Muted.

LVA [5:0] Left Voice Attenuation for Playback channel. The LSB represents -1.5 dB, 000000 = 0 dB and the range is 0 dB to -94.5 dB

LVM Left Voice Mute. 0 = Unmuted, 1 = Muted.

[05] FM ATTENUATION **DEFAULT = [0x8080]**

7	6	5	4	3	2	1	0	7	6	5	4	3	2	1	0
LFMM	RES	LFMA [5:0]						RFMM	RES	RFMA [5:0]					

RFMA [5:0] Right F Music Attenuation for the internal Music Synthesizer. The LSB represents -1.5 dB, 000000 = 0 dB and the range is 0 dB to -94.5 dB.

RFMM Right F Music Mute. 0 = Unmuted, 1 = Muted.

LFMA [5:0] Left F Music Attenuation for the internal Music Synthesizer. The LSB represents -1.5 dB, 000000 = 0 dB and the range is 0 dB to -94.5 dB.

LFMM Left F Music Mute. 0 = Unmuted, 1 = Muted.

[06] I²S(1) ATTENUATION **DEFAULT = [0x8080]**

7	6	5	4	3	2	1	0	7	6	5	4	3	2	1	0
LS1M	RES	LS1A [5:0]						RS1M	RES	RS1A [5:0]					

RS1A [5:0] Right I²S(1) Attenuation register. The LSB represents -1.5 dB, 000000 = 0 dB and the range is 0 dB to -94.5 dB.

RS1M Right I²S(1) Mute. 0 = Unmuted, 1 = Muted.

LS1A [5:0] Left I²S(1) Attenuation register. The LSB represents -1.5 dB, 000000 = 0 dB and the range is 0 dB to -94.5 dB.

LS1M Left I²S(1) Mute. 0 = Unmuted, 1 = Muted.

[07] I²S(0) ATTENUATION

DEFAULT = [0x8080]

7	6	5	4	3	2	1	0	7	6	5	4	3	2	1	0
LS0M	RES	LS0A [5:0]						RS0M	RES	RS0A [5:0]					

RS0A [5:0] Right I²S(0) Attenuation register. The LSB represents -1.5 dB, 000000 = 0 dB and the range is 0 dB to -94.5 dB.

RS0M Right I²S(0) Mute. 0 = Unmuted, 1 = Muted.

LS0A [5:0] Left I²S(0) Attenuation register. The LSB represents -1.5 dB, 000000 = 0 dB and the range is 0 dB to -94.5 dB.

LS0M Left I²S(0) Mute. 0 = Unmuted, 1 = Muted.

[08] PLAYBACK BASE COUNT

DEFAULT = [0x0000]

7	6	5	4	3	2	1	0	7	6	5	4	3	2	1	0
PBC [15:8]								PBC [7:0]							

PBC [15:0] Playback Base Count. This register is for loading the Playback DMA Count. Writing a value to this register also loads the same data into the Playback Current Count register. You must load this register when Playback Enable (PEN) is deasserted. When PEN is asserted, the Playback Current Count decrements once for every four bytes transferred via a DMA cycle. The next transfer, after zero is reached in the Playback Current Count, will generate an interrupt and reload the Playback Current Count with the value in the Playback Base Count. The Playback Base Count should always be programmed to Number Bytes divided by four, minus one ((Number Bytes/4) - 1). The circular software DMA buffer must be divisible by four to ensure proper operation.

[09] PLAYBACK CURRENT COUNT

DEFAULT = [0x0000]

7	6	5	4	3	2	1	0	7	6	5	4	3	2	1	0
PCC [15:8]								PCC [7:0]							

PCC [15:0] Playback Current Count register. Contains the current Playback DMA Count. Reads and Writes must be done when PEN is deasserted.

[10] CAPTURE BASE COUNT

DEFAULT = [0x0000]

7	6	5	4	3	2	1	0	7	6	5	4	3	2	1	0
CBC [15:8]								CBC [7:0]							

CBC [15:0] Capture Base Count. This register is for loading the Capture DMA Count. Writing a value to this register also loads the same data into the Capture Current Count register. Loading must be done when Capture Enable (CEN) is deasserted. When CEN is asserted, the Capture Current Count decrements once for every four bytes transferred via a DMA cycle. The next transfer, after zero is reached in the Capture Current Count, will generate an interrupt and reload the Capture Current Count with the value in the Capture Base Count. The Capture Base Count should always be programmed to Number Bytes divided by four, minus one ((Number Bytes/4) - 1). The circular software DMA buffer must be divisible by four to ensure proper operation.

[11] CAPTURE CURRENT COUNT

DEFAULT = [0x0000]

7	6	5	4	3	2	1	0	7	6	5	4	3	2	1	0
CCC [15:8]								CCC [7:0]							

CCC [15:0] Capture Current Count register. Contains the current Capture DMA Count. Reading and Writing must be done when CEN is deasserted.

[12] TIMER BASE COUNT

DEFAULT = [0x0000]

7	6	5	4	3	2	1	0	7	6	5	4	3	2	1	0
TBC [15:8]								TBC [7:0]							

TBC [15:0] Timer Base Count. Writing a value to this register loads data into the Timer Current Count register. Loading must be done when Timer Enable (TE) is deasserted. When TE is asserted, the Timer Current Count register decrements once for every specified time period. The time period (10 μ s or 100 ms) is programmed via the PTB bit in SS [44]. When TE is asserted, the Timer Current Count decrements once every time period. The next count, after zero is reached in the Timer Current Count register, will generate an interrupt and reload the Timer Current Count register with the value in the Timer Base Count register.

AD1816A

[13] TIMER CURRENT COUNT

DEFAULT = [0x0000]

7	6	5	4	3	2	1	0	7	6	5	4	3	2	1	0
TCC [15:8]								TCC [7:0]							

TCC [15:0] Timer DMA Current Count register. Contains the current timer count. Reading and Writing must be done when TE is deasserted.

[14] MASTER VOLUME ATTENUATION

DEFAULT = [0x0000]

7	6	5	4	3	2	1	0	7	6	5	4	3	2	1	0
LMVM	RES	LMVA [4:0]				RMVM	RES	RMVA [4:0]							

RMVA [4:0] Right Master Volume Attenuation. The LSB represents -1.5 dB, 00000 = 0 dB and the range is 0 dB to -46.5 dB. This register is added with the Hardware Volume Button Modifier value to produce the final DAC Master Volume attenuation level. See Hardware Volume Button Modifier Register description for more details.

RMVM Right Master Volume Mute. 0 = Unmuted, 1 = Muted.

LMVA [4:0] Left Master Volume Attenuation. The LSB represents -1.5 dB, 00000 = 0 dB and the range is 0 dB to -46.5 dB. This register is added with the Hardware Volume Button Modifier value to produce the final DAC Master Volume attenuation level. See Hardware Volume Button Modifier Register description for more details.

LMVM Left Master Volume Mute. 0 = Unmuted, 1 = Muted.

[15] CD GAIN/ATTENUATION

DEFAULT = [0x8888]

7	6	5	4	3	2	1	0	7	6	5	4	3	2	1	0
LCDM	RES	LCDA [4:0]				RCDM	RES	RCDA [4:0]							

RCDA [4:0] Right CD Attenuation. The LSB represents -1.5 dB, 00000 = +12 dB and the range is +12 dB to -34.5 dB.

RCDM Right CD Mute. 0 = Unmuted, 1 = Muted.

LCDA [4:0] Left CD Attenuation. The LSB represents -1.5 dB, 00000 = +12 dB and the range is +12 dB to -34.5 dB.

LCDM Left CD Mute. 0 = Unmuted, 1 = Muted.

[16] SYNTH GAIN/ATTENUATION

DEFAULT = [0x8888]

7	6	5	4	3	2	1	0	7	6	5	4	3	2	1	0
LSYM	RES	LSYA [4:0]				RSYM	RES	RSYA [4:0]							

RSYA [4:0] Right SYNTH Attenuation. The LSB represents -1.5 dB, 00000 = +12 dB and the range is +12 dB to -34.5 dB.

RSYM Right SYNTH Mute. 0 = Unmuted, 1 = Muted.

LSYA [4:0] Left SYNTH Attenuation. The LSB represents -1.5 dB, 00000 = +12 dB and the range is +12 dB to -34.5 dB.

LSYM Left SYNTH Mute. 0 = Unmuted, 1 = Muted.

[17] VID GAIN/ATTENUATION

DEFAULT = [0x8888]

7	6	5	4	3	2	1	0	7	6	5	4	3	2	1	0
LVDM	RES	LVDA [4:0]				RVDM	RES	RVDA [4:0]							

RVDA [4:0] Right VID Attenuation. The LSB represents -1.5 dB, 00000 = +12 dB and the range is +12 dB to -34.5 dB.

RVDM Right VID Mute. 0 = Unmute, 1 = Muted.

LVDA [4:0] Left VID Attenuation. The LSB represents -1.5 dB, 00000 = +12 dB and the range is +12 dB to -34.5 dB.

LVDM Left VID Mute. 0 = Unmuted, 1 = Muted.

[18] LINE GAIN/ATTENUATION

DEFAULT = [0x8888]

7	6	5	4	3	2	1	0	7	6	5	4	3	2	1	0
LLM	RES	LLA [4:0]				RLM	RES	RLA [4:0]							

RLA [4:0] Right LINE Attenuation. The LSB represents -1.5 dB, 00000 = +12 dB and the range is +12 dB to -34.5 dB.

RLM Right Line Mute. 0 = Unmuted, 1 = Muted.

LLA [4:0] Left LINE Attenuation. The LSB represents -1.5 dB, 00000 = +12 dB and the range is +12 dB to -34.5 dB.

LLM Left Line Mute. 0 = Unmuted, 1 = Muted.

[19] MIC/PHONE_IN GAIN/ATTENUATION

DEFAULT = [0x8888]

7	6	5	4	3	2	1	0	7	6	5	4	3	2	1	0
MCM	M20	RES	MCA [4:0]				PIM	RES	PIA [3:0]			RES			

PIA [3:0] PHONE_IN Attenuation. The LSB represents -3 dB, 0000 = 0 dB and the range is 0 dB to -45 dB.

PIM PHONE_IN Mute.

MCA [4:0] Microphone Attenuation. The LSB represents -1.5 dB, 00000 = +12 dB and the range is ±12 dB to -34.5 dB.

M20 Microphone 20 dB Gain. The M20-bit enables the Microphone +20 dB gain stage.

MCM Microphone Mute.

[20] ADC SOURCE SELECT AND ADC PGA

DEFAULT = [0x0000]

7	6	5	4	3	2	1	0	7	6	5	4	3	2	1	0
LAGC	LAS [2:0]		LAG [3:0]				RAGC	RAS [2:0]		RAG [3:0]					

RAG [3:0] Right ADC Gain Control ADC source select and Gain. For Gain, LSB represents +1.5 dB, 0000 = 0 dB and the range is 0 dB to +22.5 dB.

RAGC Right Automatic Gain Control (AGC) Enable, 1 = Enabled, 0 = Disabled.

LAG [3:0] Left ADC Gain Control ADC source select and Gain. For Gain, LSB represents +1.5 dB, 0000 = 0 dB and the range is 0 dB to +22.5 dB.

LAGC Left Automatic Gain Control (AGC) Enable, 1 = Enabled, 0 = Disabled.

RAS [2:0] ADC Right Input Source

000 R_LINE

001 R_OUT

010 R_CD

011 R_SYNTH

100 R_VID

101 Mono Mix

110 Reserved

111 Reserved

LAS [2:0] ADC Left Input Source

000 L_LINE

001 L_OUT

010 L_CD

011 L_SYNTH

100 L_VID

101 MIC

110 PHONE_IN

111 Reserved

Note: When the AGC is enabled, gain control settings for the ADC PGA are overridden for all inputs.

[32] CHIP CONFIGURATION

DEFAULT = [0x00F0]

7	6	5	4	3	2	1	0	7	6	5	4	3	2	1	0
WSE	CDE	RES	CNP	RES			COF [3:0]			I ² SF1 [1:0]	I ² SF0 [1:0]				

I²SF0 [1:0] I²S Port Configuration for serial data type.

I²SF1 [1:0]

00	Disabled
01	Right Justified
10	I ² S Justified
11	Left Justified

COF [3:0] Clock Output Frequency. Programmable clock output on PCLKO pin is determined using the following formula $PCLKO = 256 \times PCR / 2^{COF}$ where COF = 0:11 and PCR is the value of the Programmable Clock Rate Register, SS [38]. If COF > 11, then PCLKO is disabled.

CNP Capture not equal to Playback.

0 = Capture equals Playback. The capture sample rate is determined by the playback sample rate in SS [02].
1 = Capture not equal to Playback.

CDE CD Enable, Set to "1" when a CD player is connected to I²S (0), maps SoundBlaster CD mixer controls from the analog CD attenuator inputs to I²S (0) serial port.

WSE Sound System Enable.

0 = SoundBlaster Mode.
1 = Sound System Mode under Windows.

Note: When in SoundBlaster Mode, the Codec ADC and DAC channels will be used solely for converting SoundBlaster data.

AD1816A

[33] DSP CONFIGURATION

DEFAULT = [0x0000]

7	6	5	4	3	2	1	0	7	6	5	4	3	2	1	0
DS1	DS0	DIT	RES	ADR	I1T	I0T	CPI	PBI	FMI	I1I	I0I	DFS [2:0]			

DFS [2:0] DSP Frame Sync Source. Sets the DSP Port Frame Sync according to the following source.

- 000—Maximum Frame Rate
- 001—I²S(0) Sample Rate
- 010—I²S(1) Sample Rate
- 011—Music Synthesizer Sample Rate
- 100—Sound System Playback Sample Rate
- 101—Sound System Capture Sample Rate
- 111—Reserved

- I0I I²S(0) Data Intercept. 0 = Disable, 1 = Intercept I²S(0) Data Enabled.
- I1I I²S(1) Data Intercept. 0 = Disable, 1 = Intercept I²S(1) Data Enabled.
- FMI FM Music Synthesizer Data Intercept. 0 = Disable, 1 = Intercept FM Music Data Enabled.
- PBI Playback Data Intercept. 0 = Disable, 1 = Intercept Playback Data Enabled.
- CPI Capture Data Intercept. 0 = Disable, 1 = Intercept Capture Data Enabled.
- I0T I²S(0) Takeover Data. 0 = Disable, 1 = Enabled.
- I1T I²S(1) Takeover Data. 0 = Disable, 1 = Enabled.
- ADR Audio Resync. Writing “1” causes all FIFOs in the DSP port to be re-initialized.
- DIT DSP Interrupt. A write to this bit causes an ISA interrupt if DIE is asserted.
- DS0 DSP Mailbox 0 Status. 0 = last access indicates read, 1 = last access indicates write.
- DS1 DSP Mailbox 1 Status. 0 = last access indicates read, 1 = last access indicates write.

[34] FM SAMPLE RATE

DEFAULT = [0x5622]

7	6	5	4	3	2	1	0	7	6	5	4	3	2	1	0
FMSR [15:8]								FMSR [7:0]							

FMSR [15:0] F Music Sample Rate register. The sample rate can be programmed from 4 kHz to 27.6 kHz in 1 hertz increments.

[35] I²S(1) SAMPLE RATE

DEFAULT = [0xAC44]

7	6	5	4	3	2	1	0	7	6	5	4	3	2	1	0
S1SR [15:8]								S1SR [7:0]							

S1SR [15:0] I²S(1) Sample Rate register. The sample rate can be programmed from 4 kHz to 55.2 kHz in 1 hertz increments. Programming this register has no effect unless I²SF1 [1:0] is enabled.

[36] I²S(0) SAMPLE RATE

DEFAULT = [0xAC44]

7	6	5	4	3	2	1	0	7	6	5	4	3	2	1	0
S0SR [15:8]								S0SR [7:0]							

S0SR [15:0] I²S(0) Sample Rate register. The sample rate can be programmed from 4 kHz to 55.2 kHz in 1 hertz increments. Programming this register has no effect unless I²SF0 [1:0] is enabled.

[37] RESERVED

DEFAULT = [0x0000]

7	6	5	4	3	2	1	0	7	6	5	4	3	2	1	0
RES								RES							

[38] PROGRAMMABLE CLOCK RATE

DEFAULT = [0xAC44]

7	6	5	4	3	2	1	0	7	6	5	4	3	2	1	0
PCR [15:8]								PCR [7:0]							

PCR [15:0] Programmable Clock Rate register. The clock rate can be programmed from 25 kHz to 50 kHz in 1 hertz increments. This register is only valid when the COF bits in SS [32] are set for the multiplier factor. PCLKO = 256 × PCR/2^{COF}. See SS [32] for determining the value of COF.

[39] 3D Phat Stereo Control and PHONE_OUT Attenuation

DEFAULT = [0x8000]

7	6	5	4	3	2	1	0	7	6	5	4	3	2	1	0
3DDM	RES	3DD [3:0]			RES	POM	RES	POA [4:0]							

POA [4:0] PHONE-OUT Attenuation. The LSB represents -1.5 dB, 0000 = 0 dB and the range is 0 dB to -46.5 dB.

POM PHONE-OUT Mute. 0 = Unmuted, 1 = Muted.
 3DD [3:0] 3D Depth Phat Stereo Enhancement Control. The LSB represents $6\frac{2}{3}\%$ phase expansion, 0000 = 0% and the range is 0% to 100%.
 3DDM 3D Depth Mute. Writing a "1" to this bit has the same affect as writing 0s to 3DD [3:0] bits, and causes the Phat 3D Stereo Enhancement to be turned off. 0 = Phat Stereo is on, 1 = Phat Stereo is off.

[40] RESERVED **DEFAULT = [0x0000]**

7	6	5	4	3	2	1	0	7	6	5	4	3	2	1	0
RES								RES							

[41] HARDWARE VOLUME BUTTON MODIFIER **DEFAULT = [0xXX1B]**

7	6	5	4	3	2	1	0	7	6	5	4	3	2	1	0
RES								VMU	VUP	VDN	BM [4:0]				

BM [4:0] Button Modifier
 VDM Volume Down
 VUP Volume Up
 VMU Volume Mute

This register contains a Master Volume attenuation offset, which can be incremented or decremented via the Hardware Volume Pins. This register is summed with the Master Volume attenuation to produce the actual Master Volume DAC attenuation. A momentary grounding of greater than 50 ms on the $\overline{\text{VOL_UP}}$ pin will cause a decrement (decrease in Attenuation) in this register. Holding the pin LO for greater than 200 ms will cause an auto-decrement every 200 ms. This is also true for a momentary grounding of the $\overline{\text{VOL_DN}}$ pin. A momentary grounding of both the $\overline{\text{VOL_UP}}$ and $\overline{\text{VOL_DN}}$ causes a mute and no increment or decrement to occur.

When Muted, an unmute is possible by a momentary grounding of both the $\overline{\text{VOL_UP}}$ and $\overline{\text{VOL_DN}}$ pins together, a momentary grounding of $\overline{\text{VOL_UP}}$ (this also causes a volume increase), a momentary grounding of $\overline{\text{VOL_DN}}$ (this also causes a volume decrease) or a write of "0" to the VI bit in SS [BASE+1].

[42] DSP MAILBOX 0 **DEFAULT = [0x0000]**

7	6	5	4	3	2	1	0	7	6	5	4	3	2	1	0
MB0R [15:8]								MB0R [7:0]							

MB0R [15:0] This register is used to send data and control information to and from the DSP.

[43] DSP MAILBOX 1 **DEFAULT = [0x0000]**

7	6	5	4	3	2	1	0	7	6	5	4	3	2	1	0
MB1R [15:8]								MB1R [7:0]							

MB1R [15:0] This register is used to send data and control information to and from the DSP.

[44] POWERDOWN AND TIMER CONTROL **DEFAULT = [0x0000]**

7	6	5	4	3	2	1	0	7	6	5	4	3	2	1	0
CPD	RES	PIW	PIR	PAA	PDA	PDP	PTB	3D	PD3D	GPSP	RES	DM	RES		

The AD1816A supports a timeout mechanism used in conjunction with the Timer Base Count and Timer Current Count registers to generate a power-down interrupt. This interrupt allows software to power down the entire chip by setting the CPD bit. This power-down control feature lets users program a time interval from 1 ms to approximately 1.8 hours in 1 ms increments. Five power-down count reload enable bits are used to reload the Timer Current Count from the Timer Base Count when activity is seen on that particular channel.

Programming Example: Generate Interrupt if No ISA Reads or Writes occur within 15 Minutes.

- 1) Write [SSBASE+0] with 0x0C ; Write Indirect address for TIMER BASE COUNT "register 12"
- 2) Write [SSBASE+2] with 0x28 ; Write TIMER BASE COUNT with (15 min \times 60 sec/min \times 100 ms) = 0x2328; Note: PTB = 1, timer decrements every 100 ms
- 3) Write [SSBASE+3] with 0x23 ; Write High byte of TIMER BASE COUNT
- 4) Write [SSBASE+0] with 0x2C ; Write Indirect address for POWER-DOWN and TIMER CONTROL register
- 5) Write [SSBASE+2] with 0x00 ; Write Low byte of POWER-DOWN and TIMER CONTROL register
- 6) Write [SSBASE+3] with 0x31 ; Set Enable bits for PIW and PIR
- 7) Write [SSBASE+0] with 0x01 ; Write Indirect address for INTERRUPT CONFIG register
- 8) Write [SSBASE+2] with 0x82 ; Set the TE (Timer Enable) bit
- 9) Write [SSBASE+3] with 0x20 ; Set the TIE (Timer Interrupt Enable) bit

AD1816A

- DM DAC Mute. This bit mutes the digital DAC output entering the analog mixer.
- GPSP Game Port Speed Select. Selects the operating speed of the game port.
 - 0 Slow Game Port
 - 1 Fast Game Port
- PD3D Power-Down 3D. Turns off internal Phat Stereo circuitry.
 - 0 On
 - 1 Off
- 3D 3D Analog Mixer Bypass. Allows the analog output of the D/A converters to bypass the Phat Stereo Circuit. Enables ultimate flexibility for mixing and any combination of 3D enhanced analog signals or non-3D enhanced signals with the DAC output.
 - 0 3D Phat Stereo Enabled for DAC Output
 - 1 3D Phat Stereo Bypassed for DAC Output
- PTB Power-Down Time Base. 1 = timer set to 100 ms, 0 = timer set to 10 μ s.
- PDP Power-down count reload on DSP Port enabled; "1" = Reload count if DSP Port enabled. DSP Port is enabled when Slot 0 of SDI of the DSP Serial Port Input is Alive (Bit 7 = 1).
- PDA Power-down count reload on Digital Activity; "1" = Reload count on Digital Activity. Digital Activity is defined as any activity on (I²S0, I²S1, FM or PLAYBACK).
- PAA Power-down count reload on Analog Activity; "1" = Reload count on Analog Activity. Analog Activity is defined as any analog input unmuted (LINE, CD, SYNTH, MIC, PHONE_IN) or MASTER VOLUME unmuting.
- PIR Power-down count reload on ISA Read; "1" = Reload count on ISA read. ISA Read is defined as a read from any active logical device inside the AD1816A.
- PIW Power-down count reload on ISA Write; "1" = Reload count on ISA write. ISA Write defined as a write to any active logical device inside the AD1816A.
- CPD Chip Power-down
 - 1 Power-Down;
 - 0 Power-Up

For Power-up, software should poll the [SSBASE+0] CRY bit for "1" before writing or reading any logical device.

[45] VERSION ID								DEFAULT = [0xXXXX]							
7	6	5	4	3	2	1	0	7	6	5	4	3	2	1	0
VER [15:8]								VER [7:0]							

[46] RESERVED								DEFAULT = [0x0000]							
7	6	5	4	3	2	1	0	7	6	5	4	3	2	1	0
RES								RES							

Test register. Should never be written or read under normal operation.

SB Pro; AdLib Registers

The AD1816A contains sets of ISA Bus registers (ports) that correspond to those used by the SoundBlaster Pro audio card from Creative Labs and the AdLib audio card from AdLib Multimedia. Table IX lists the ISA Bus SoundBlaster Pro registers. Table X lists the ISA Bus AdLib registers. Because the AdLib registers are a subset of those in the SoundBlaster card, you can find complete information on using both of these registers in the *Developer Kit for SoundBlaster Series, 2nd ed.* © 1993, Creative Labs, Inc., 1901 McCarthy Blvd., Milpitas, CA 95035.

Table IX. SoundBlaster Pro ISA Bus Registers

Register Name	ISA Bus Address
Music0: Address (w), Status (r)	(SB Base) Relocatable in range 0x100 – 0x3F0
Music0: Data (w)	(SB Base+1)
Music1: Address (w)	(SB Base+2)
Music1: Data (w)	(SB Base+3)
Mixer Address (w)	(SB Base+4)
Mixer Data (w)	(SB Base+5)
Reset (w)	(SB Base+6)
Music0: Address (w)	(SB Base+8)
Music0: Data (w)	(SB Base+9)
Input Data (r)	(SB Base+A)
Status (r), Output Data (w)	(SB Base+C)
Status (r)	(SB Base+E)

Table X. AdLib ISA Bus Registers

Register Name	ISA Bus Address
Music0: Address (w), Status (r)	(AdLib Base) Relocatable in range 0x100 – 0x3F8
Music0: Data (w)	(AdLib Base+1)
Music1: Address (w)	(AdLib Base+2)
Music1: Data (w)	(AdLib Base+3)

MPU-401 Registers

The AD1816A contains a set of ISA Bus registers (ports) that correspond to those used by the ISA bus MIDI audio interface cards. Table XI lists the ISA Bus MIDI registers. These registers support commands and data transfers described in *MIDI 1.0 Detailed Specification and Standard MIDI Files 1.0*, © 1994, MIDI Manufacturers Association, PO Box 3173 La Habra, CA 90632-3173.

Table XI. MPU-401 ISA Bus Registers

Register Name	Address
MIDI Data (r/w)	(MIDI Base) Relocatable in range 0x100 to 0x3FE
MIDI Status (r), Command (w)	(MIDI Base+1)

0x(MIDI Base+1)

BIT	7	6	5	4	3	2	1	0
STATE	1	0	0	0	0	0	0	0
NAME	DRR	DSR	RESERVED					

- DSR (R) Data Send Ready. When read, this bit indicates that you can (0) or cannot (1) write to the MIDI Data register. (Full = 1, Empty = 0)
- DRR (R) Data Receive Ready. When read, this bit indicates that you can (0) or cannot (1) read from the MIDI Data register. (Unreadable = 1, Readable = 0)
- CMD [7:0] (W) MIDI Command. Write MPU-401 commands to bits [7:0] of this register.

NOTES

The AD1816A supports *only* the MPU-401 0xFF (reset) and 0x3F (UART) commands. The controller powers setup for Smart mode, but must be put in pass-through mode. To start MIDI operations, send a reset command (0xFF) and then send a UART mode command (0x3F). The MPU-401 data register contains an acknowledge byte (0xFE) after each command transfer unless it is in UART mode..

All commands return an ACK byte in “smart” mode.

Status commands (0xAx) return ACK and a data byte; all other commands return ACK.

All commands except reset (0xFF) are ignored in UART mode. No ACK bytes are returned.

“Smart” mode data transfers are not supported.

Game Port Registers

The AD1816A contains a Game Port ISA Bus Register that is compatible with the IBM joystick standard.

Table XII. Game Port ISA Bus Registers

Register Name	Address
Game Port I/O	(Game Port Base+0 to Game Port Base+7) Relocatable in the range 0x100 to 0x3F8

APPENDIX A

PLUG AND PLAY INTERNAL ROM

Note: All addresses are depicted in hexadecimal notation.

Vendor ID: ADS7181

Serial Number: FFFFFFFF

Checksum: 2F

PNP Version: 1.0, vendor version: 20

ASCII string: "Analog Devices AD1816A"

Logical Device ID: ADS7180

not a boot device, implements PNP register(s) 31

Start dependent function, best config

IRQ: channel(s) 5 7

type(s) active-high, edge-triggered

DMA: channel(s) 1

Type F, count-by-byte, nonbus-mastering, 8-bit only

DMA: channel(s) 0 1 3

Type F, count-by-byte, nonbus-mastering, 8-bit only

I/O: 16-bit decode, range [0220,0240] mod 20, length 10

I/O: 16-bit decode, range [0388,0388] mod 08, length 04

I/O: 16-bit decode, range [0500,0560] mod 10, length 10

Start dependent function, acceptable config

IRQ: channel(s) 5 7 10

type(s) active-high, edge-triggered

DMA: channel(s) 0 1 3

Type F, count-by-byte, nonbus-mastering, 8-bit only

DMA: channel(s) 0 1 3

Type F, count-by-byte, nonbus-mastering, 8-bit only

I/O: 16-bit decode, range [0220,0240] mod 20, length 10

I/O: 16-bit decode, range [0388,0388] mod 08, length 04

I/O: 16-bit decode, range [0500,0560] mod 10, length 10

Start dependent function, acceptable config

IRQ: channel(s) 5 7 9 10 11 15

type(s) active-high, edge-triggered

DMA: channel(s) 0 1 3

Type F, count-by-byte, nonbus-mastering, 8-bit only

DMA: channel(s) 0 1 3

Type F, count-by-byte, nonbus-mastering, 8-bit only

I/O: 16-bit decode, range [0220,02E0] mod 20, length 10

I/O: 16-bit decode, range [0388,03B8] mod 08, length 04

I/O: 16-bit decode, range [0500,0560] mod 10, length 10

Start dependent function, suboptimal config

IRQ: channel(s) 5 7 9 10 11 15

type(s) active-high, edge-triggered

DMA: channel(s) 0 1 3

Type F, count-by-byte, nonbus-mastering, 8-bit only

DMA: NULL

I/O: 16-bit decode, range [0220,02E0] mod 20, length 10

I/O: 16-bit decode, range [0388,03B8] mod 08, length 04

I/O: 16-bit decode, range [0500,0560] mod 10, length 10

End all dependent functions

Logical Device ID: ADS7181

not a boot device, implements PNP register(s) 31

Compatible Device ID: PNPB006

Start dependent function, best config

IRQ: channel(s) 5 7 9 11

type(s) active-high, edge-triggered

I/O: 16-bit decode, range [0300,0330] mod 30, length 02

Start dependent function, acceptable config

IRQ: channel(s) 5 7 9 10 11 15

type(s) active-high, edge-triggered

I/O: 16-bit decode, range [0300,0420] mod 30, length 02

End all dependent functions

Logical Device ID: ADS7182

not a boot device, implements PNP register(s) 31

Compatible Device ID: PNPB02F

Start dependent function, best config

I/O: 16-bit decode, range [0200,0200] mod 08, length 08

Start dependent function, acceptable config

I/O: 16-bit decode, range [0200,0208] mod 08, length 08

End all dependent functions

End:

PLUG AND PLAY KEY AND “ALTERNATE KEY” SEQUENCES

One additional feature of the AD1816A is an alternate programming method used, for example, if a BIOS wants to assume control of the AD1816A and present DEVNODES to the OS (rather than having the device participate in Plug and Play enumeration). The following technique may be used.

Instead of the normal 32 byte Plug and Play key sequence, an alternate 126 byte key is used. After the 126 byte key, the AD1816A device will transition to the Plug and Play “sleep” state. It can then be programmed as usual using the standard Plug and Play ports. After programming, the AD1816A should be sent to the Plug and Play “WFK” (wait for key) state. Once the AD1816A has seen the alternate key, it will no longer parse for the Plug and Play key (and therefore never participate in Plug and Play enumeration). It can be reprogrammed by reissuing the alternate key again.

Both the Plug and Play key and the alternate key are sequences of writes to the Plug and Play address register, 0x279. Below are the ISA data values of both keys.

This is the standard Plug and Play sequence:

6a	b5	da	ed	f6	fb	7d	be	df	6f	37	1b	0d	86	c3	61
b0	58	2c	16	8b	45	a2	d1	e8	74	3a	9d	ce	e7	73	39

This is the longer, 126-byte alternate key. It is generated by the function:

$$f[n+1] = (f[n] \gg 1) | (((f[n] \wedge (f[n] \gg 1)) \& 0x01) \ll 6) \quad f[0] = 0x01$$

01	40	20	10	08	04	02	41	60	30	18	0c	06	43	21	50
28	14	0a	45	62	71	78	3c	1e	4f	27	13	09	44	22	51
68	34	1a	4d	66	73	39	5c	2e	57	2b	15	4a	65	72	79
7c	3e	5f	2f	17	0b	05	42	61	70	38	1c	0e	47	23	11
48	24	12	49	64	32	59	6c	36	5b	2d	56	6b	35	5a	6d
76	7b	3d	5e	6f	37	1b	0d	46	63	31	58	2c	16	4b	25
52	69	74	3a	5d	6e	77	3b	1d	4e	67	33	19	4c	26	53
29	54	2a	55	6a	75	7a	7d	7e	7f	3f	1f	0f	07		

AD1816A

AD1816 AND AD1816A COMPATIBILITY

The AD1816 and AD1816A are pin for pin and functionally compatible. The AD1816A may be dropped directly into an existing AD1816 design. However, the AD1816A has greater pin assignment flexibility to accommodate a wider range of applications and for controlling extra logical devices such as a modem chip set or an Enhanced IDE controller. Pin assignments are controlled by the external EEPROM. Consequently, the optional EEPROM must be reprogrammed to configure the AD1816A.

USING AN EEPROM WITH THE AD1816 OR AD1816A

The AD1816 and AD1816A support an optional Plug and Play resource ROM. If present, the ROM must be a two-wire serial device (e.g. Xicor X24C02) and the clock and data lines should be wired to EE_CLK and EE_DATA pins; pull-up resistors are required on both signals. The EEPROM's A2 and A1 pins (also A0 for 256-byte EEPROMs) must all be tied to ground. The write control pin (WC*) must be tied to power if you wish to program the EEPROM in place; otherwise, we recommend tying it to ground to prevent accidental writes.

The EEPROM interface logic examines the state of the EE_CLK pin shortly after RESET is deasserted and whenever the Plug and Play reset register (02h) is written with a value X such that $(X \& 1] \neq 0)$. If an EEPROM is connected, EE_CLK is pulled high and the EEPROM logic attempts to read the first ROM byte (page 0, byte 0). If EE_CLK is tied low, the internal ROM is used; in this case EE_DATA is used to set the state of VOL_EN, and should also be tied high or low. EE_CLK is not used as an input at any other time.

The initial part of the ROM is not part of the Plug and Play resource data. It consists of a number of flags that enable optional functionality. The number of flag bytes and the purpose of each bit depend on whether an AD1816 or an AD1816A is being used.

AD1816 FLAG BYTE

The AD1816 has a single flag byte that is used as shown below:

7	6	5	4	3	2	1	0
1	0	0	XTRA_SIZE VOL_SEL	VOL_EN	XTRA_IRQ	XTRA_EN	MODEM_EN

MODEM_EN Program to one to enable the modem logical device. This logical device has an I/O range and an IRQ. The I/O range has the following requirements:

- Length of eight bytes
- Alignment of eight bytes
- 16-bit address decode

Program to zero to enable I²S Port 1.

XTRA_EN Program to one to enable the XTRA logical device. This logical device has an I/O range, an optional IRQ, and an optional DMA. The I/O range has the following requirements:

- Length of eight bytes or 16 bytes, selectable by XTRA_SIZE
- Alignment of eight bytes or 16 bytes, matches length
- 16-bit address decode

Program to zero to enable the DSP serial port.

XTRA_IRQ Program to one to include an IRQ in the XTRA logical device. When enabled, the IRQ level and type are programmed through PnP registers 0x70 and 0x71. (Note: For the 1816, the IRQ type is hard coded and rising edge triggered.)

VOL_EN Program to one to enable hardware volume control.

**XTRA_SIZE/
VOL_SEL** The function of this bit depends on XTRA_EN. If XTRA_EN is one, this bit selects the size of the XTRA device's I/O range. Program to one to make the XTRA logical device I/O length 16 bytes. Program to zero to set the XTRA logical device I/O length to eight bytes. The alignment specified in the resource data must be an integer multiple of the length. If XTRA_EN is zero (and VOL_EN is one), then this bit selects the location of the hardware volume control pins. Program to zero to replace I²S0 with the volume control pins; program to one to replace the SPORT.

The three MSBs in the first byte of the AD1816 EEPROM are used to verify that the EEPROM data is valid. The bits are compared to the values shown; if a mismatch is found, then the EEPROM will be ignored. The internal ROM will be used to perform PnP enumeration, and the MODEM and XTRA logical devices will not be available. Hardware volume will be enabled on the I²S0 port. The SPORT is disabled.

USING THE AD1816 WITHOUT AN EEPROM

If the EEPROM is absent (EE_CLK pin = GND), the flags are set as shown below:

MODEM_EN = XTRA_EN = XTRA_IRQ = VOL_SEL = 0

VOL_EN = EE_DATA pin

AD1816A FLAG BYTES

The AD1816A has four flag bytes that are used as shown below:

(*) AD1816-compatible setting.

Byte 0

7	6	5	4	3	2	1	0
1	0	0	XTRA_HV	I ² S ₀ _HV	SUPER_EN	XTRA_EN	MODEM_EN

MODEM_EN Program to one to enable the modem logical device. This logical device has an I/O range and an IRQ. The I/O range has the following requirements:

- Length of eight bytes
 - Alignment of eight bytes
 - 16-bit address decode
- Program to zero to enable I²S Port 1 (SUPER_EN and IRQ_EN must also be zero).

XTRA_EN Program to one to enable the XTRA logical device. This logical device has an I/O range, an optional IRQ, and an optional DMA. The I/O range has the following requirements:

- Length of 1 to 16 bytes, selectable by XTRASZ0[3:0]
- Alignment of 1 to 16 bytes, matches length
- 16-bit address decode

A second I/O range is available (see XTRA_CS). Program to zero to enable the DSP serial port (XTRA_HV must also be zero).

SUPER_EN Program to one to merge the XTRA and modem logical devices. If this bit is set to one, XTRA_EN and IRQ_EN must be set to one and MODEM_EN must be set to zero. The combined device has up to two I/O ranges, two IRQs and one DMA. The two I/O ranges are both taken from the XTRA device; the modem I/O range is disabled. The first IRQ is the XTRA device IRQ, the second is the modem IRQ. Program to zero for distinct modem and XTRA devices. (*)

I²S₀_HV Program to one to enable hardware volume inputs on the I²S port 0 pins.

XTRA_HV Program to one to enable hardware volume inputs on the DSP serial port pins. Do not enable both XTRA_HV and I²S₀_HV. Program to zero to enable the XTRA device DMA or the DSP serial port.

The three MSBs in the first byte of the AD1816A EEPROM are used to verify that the EEPROM data is valid. The bits are compared to the values shown; if a mismatch is found, the EEPROM will be ignored. The internal ROM will be used to perform PnP enumeration, and the MODEM and XTRA logical devices will not be available. Hardware volume will be enabled on the I²S₀ port. The SPORT is disabled.

Byte 1

7	6	5	4	3	2	1	0
RESERVED			0	0	RSTB_EN	IRQSEL3_9	IRQSEL12_13

IRQSEL12_13 Program to one to enable IRQ 13.
Program to zero to enable IRQ 12.
IRQ_EN must be one and MODEM_EN must be zero, or this bit has no effect.

IRQSEL3_9 Program to one to enable IRQ 9.
Program to zero to enable IRQ 3. (*)
MODEM_EN or IRQ_EN must be one, or this bit has no effect.

RSTB_EN Program to one to enable an active-low RESET output on the XCTRL0 pin.
Program to zero to enable XCTRL0/PCLKO. (*)

AD1816A

Byte 2

7	6	5	4	3	2	1	0
IRQSEL4_9_11	IRQSEL9_14	IRQSEL11_15	IRQSEL4_10	XTRASZ0[3:0]			

XTRASZ0[3:0] Sets the XTRA device I/O range 0 length. The XTRASZ0 bits set the length of the first XTRA device I/O range as follows:

XTRASZ0	I/O Range Length
0000	16
1000	8
1100	4
1110	2
1111	1

All other combinations should be avoided.

IRQSEL4_10 Program to one to enable IRQ 10. (*, if MODEM_EN is zero)
Program to zero to enable IRQ 4. (*, if MODEM_EN is one)

IRQSEL11_15 Program to one to enable IRQ 15. (*)
Program to zero to enable IRQ 11.

IRQSEL9_14 Program to one to enable IRQ 14.
Program to zero to enable IRQ 9. (*)

IRQSEL4_9_11 Program to one to enable IRQ 11. (*)
Program to zero to enable IRQ 4 (if MODEM_EN is one) or IRQ 9 (if MODEM_EN is zero).

Byte 3

7	6	5	4	3	2	1	0
XTRASZ1[3:0]				XTRA_CS	IRQ_EN	MIRQINV	XIRQINV

XIRQINV Program to one to make LD_IRQ active-low.
Program to zero to make LD_IRQ active-high. (*)

MIRQINV Program to one to make MDM_IRQ active-low.
Program to zero to make MDM_IRQ active-high. (*)

IRQ_EN Program to one to enable additional IRQ options on the ISA bus. If MODEM_EN is zero, then two IRQs are added; if MODEM_EN is one, this bit is ignored. Program to zero to enable I²S port 1 (SUPER_EN and MODEM_EN must also be zero). (*)

XTRA_CS Program to one to enable a second I/O range for the XTRA or SUPER logical devices. It is identical to the first I/O range, except its size is controlled by XTRASZ1[3:0]. Program to zero to enable the XCTR1/RING_IN pin. (*) Always considered to be zero if XTRA_EN is zero.

XTRASZ1[3:0] Sets the XTRA device I/O range one length. The XTRASZ1 bits set the length of the second XTRA device I/O range as follows:

XTRASZ1	I/O Range Length
0000	16
1000	8
1100	4
1110	2
1111	1

All other combinations should be avoided.

USING THE AD1816A WITHOUT AN EEPROM

If the EEPROM is absent (EE_CLK pin = GND), then the flags are set as shown below:

MODEM_EN = XTRA_EN = SUPER_EN = XTRA_HV = RSTB_EN = IRQ_EN = 0

IRQSEL9_14 = MIRQINV = XIRQINV = 0

IRQSEL4_10 = IRQSEL11_15 = IRQSEL4_9_11 = 1

I²S0_HV = EE_DATA pin

MAPPING THE AD1816 EEPROM INTO THE AD1816A EEPROM

The equations below map AD1816 flags onto AD1816A flags:

MODEM_EN = MODEM_EN
 XTRA_EN = XTRA_EN
 SUPER_EN = 0
 $I^2S0_HV = VOL_EN * \overline{VOL_SEL}$
 $XTRA_HV = VOL_EN * \overline{VOL_SEL}$
 IRQSEL12_13 = X (don't care)
 IRQSEL3_9 = 0
 RSTB_EN = 0
 $XTRASZ0[3] = \overline{XTRA_SIZE}$
 $XTRASZ0[2:0] = 000$
 $IRQSEL4_10 = \overline{MODEM_EN}$
 $IRQSEL11_15 = 1$
 $IRQSEL9_14 = 0$
 $IRQSEL4_9_11 = 1$
 XIRQINV = 0
 MIRQINV = 0
 IRQ_EN = 0
 XTRA_CS = 0
 $XTRASZ1[3:0] = XXXX$ (don't care)

PIN MUXING IN THE AD1816 AND AD1816A

Some AD1816 and AD1816A options are mutually exclusive because there are a limited number of pins on the device to support them all. The tables below map functions to pin, and show how the flags must be set to assign functions to pins. For each pin, the first function listed is the default; that function is used if the EEPROM is absent or invalid.

Table XIII. AD1816 Pin Muxing

PQFP	TQFP	Pin Function	I/O	Flags Required
1	99	I^2S0_DATA	I	$\overline{VOL_EN} + (\overline{XTRA_EN} * \overline{VOL_SEL})$
		$\overline{VOL_UP}$	I	$VOL_EN * (XTRA_EN + \overline{VOL_SEL})$
2	100	I^2S0_LRCLK	I	$\overline{VOL_EN} + (\overline{XTRA_EN} * \overline{VOL_SEL})$
		$\overline{VOL_DN}$	I	$VOL_EN * (XTRA_EN + \overline{VOL_SEL})$
3	1	I^2S0_BCLK	I	$\overline{VOL_EN} + (\overline{XTRA_EN} * \overline{VOL_SEL})$
		GND	I	$VOL_EN * (XTRA_EN + \overline{VOL_SEL})$
77	75	IRQ(10)	O (1)	$\overline{MODEM_EN}$
		IRQ(4)	O (1)	$\overline{MODEM_EN}$
81	79	I^2S1_DATA	I	$\overline{MODEM_EN}$
		IRQ(3)	O (1)	$\overline{MODEM_EN}$
82	80	I^2S1_BCLK	I	$\overline{MODEM_EN}$
		MDM_IRQ	I	$\overline{MODEM_EN}$
83	81	I^2S1_LRCLK	I	$\overline{MODEM_EN}$
		MDM_SEL	O (2)	$\overline{MODEM_EN}$
97	95	SPORT_SCLK	O	$\overline{XTRA_EN} * (\overline{VOL_EN} * \overline{VOL_SEL})$
		$\overline{LD_SEL}$	O	$XTRA_EN$
		No Connect	O	$\overline{XTRA_EN} * VOL_EN * \overline{VOL_SEL}$
98	96	SPORT_SDFS	O (2)	$\overline{XTRA_EN} * (\overline{VOL_EN} * \overline{VOL_SEL})$
		$\overline{LD_DRQ}$	I	$XTRA_EN$
		$\overline{VOL_UP}$	I	$\overline{XTRA_EN} * (VOL_EN * \overline{VOL_SEL})$
99	97	SPORT_SDO	O	$\overline{XTRA_EN} * (\overline{VOL_EN} * \overline{VOL_SEL})$
		$\overline{LD_DACK}$	O	$XTRA_EN$
		No Connect	O	$\overline{XTRA_EN} * VOL_EN * \overline{VOL_SEL}$
100	98	SPORT_SDI	I	$\overline{XTRA_EN} * (\overline{VOL_EN} * \overline{VOL_SEL})$
		$\overline{LD_IRQ}$	I	$XTRA_EN * XTRA_IRQ$
		$\overline{VOL_DN}$	I	$\overline{XTRA_EN} * (VOL_EN * \overline{VOL_SEL})$
		GND	I	$\overline{XTRA_EN} * \overline{XTRA_IRQ}$

(1) IRQ pins are three-stated if not assigned to a logical device.

(2) A pull-up or pull-down resistor may be required if EEPROM is used, because this pin is three-stated while EEPROM is read.

AD1816A

Table XIV. AD1816A Pin Muxing

PQFP	TQFP	Pin Function	I/O	Flags Required
1	99	I ² S0_DATA	I	I ² S0_HV
		VOL_UP	I	I ² S0_HV
2	100	I ² S0_LRCLK	I	I ² S0_HV
		VOL_DN	I	I ² S0_HV
3	1	I ² S0_BCLK	I	I ² S0_HV
		GND	I	I ² S0_HV
68	66	XCTL0/PCLKO	O	RSTB_EN
		PNPRST	O	RSTB_EN
69	67	XCTL1/RING	O (1)	XTRA_EN + XTRA_CS
		LD_SEL1	O	XTRA_EN * XTRA_CS
75	73	IRQ(15)	O (2)	IRQSEL15_11
		IRQ(11)	O (2)	IRQSEL15_11
76	74	IRQ(11)	O (2)	IRQSEL4_9_11
		IRQ(9)	O (2)	IRQSEL4_9_11 * MODEM_EN
		IRQ(4)	O (2)	IRQSEL4_9_11 * MODEM_EN
77	75	IRQ(10)	O (2)	IRQSEL4_10
		IRQ(4)	O (2)	IRQSEL4_10
78	76	IRQ(9)	O (2)	IRQSEL9_14
		IRQ(14)	O (2)	IRQSEL9_14
81	79	I ² S1_DATA	I	MODEM_EN * SUPER_EN * IRQ_EN
		IRQ(3)	O (2)	(MODEM_EN + SUPER_EN + IRQ_EN) * IRQSEL3_9
82	80	IRQ(9)	O (2)	(MODEM_EN + SUPER_EN + IRQ_EN) * IRQSEL3_9
		I ² S1_BCLK	I	MODEM_EN
83	81	MDM_IRQ	I	MODEM_EN
		I ² S1_LRCLK	I	MODEM_EN * SUPER_EN * IRQ_EN
		MDM_SEL	O (4)	MODEM_EN * SUPER_EN
		IRQ(12)	O (2)	(MODEM_EN + SUPER_EN) * IRQ_EN * IRQSEL12_13
		IRQ(13)	O (2)	(MODEM_EN + SUPER_EN) * IRQ_EN * IRQSEL12_13
97	95	SPORT_SCLK	O	XTRA_EN * XTRA_HV
		LD_SEL0	O	XTRA_EN
		No Connect	O	XTRA_EN * XTRA_HV
98	96	SPORT_SDFS	O (3)	XTRA_EN * XTRA_HV
		LD_DRQ	I	XTRA_EN * XTRA_HV
		VOL_UP	I	XTRA_HV
99	97	SPORT_SDO	O (3)	XTRA_EN * XTRA_HV
		LD_DACK	O (3)	XTRA_EN * XTRA_HV
		VOL_DN	I	(XTRA_EN + XTRA_CS) * XTRA_HV
		GND	I	XTRA_EN * XTRA_HV * XTRA_CS
100	98	SPORT_SDI	I	XTRA_EN * XTRA_HV
		LD_IRQ	I	XTRA_EN
		VOL_DN	I	XTRA_EN * XTRA_HV * XTRA_CS
		GND	I	XTRA_EN * XTRA_HV * XTRA_CS

(1) Open-drain driver with internal weak pull-up.

(2) PC_IRQ pins are three-stated if not assigned to a logical device.

(3) A pull-up or pull-down resistor may be required if EEPROM is used, because this pin is three-stated while EEPROM is read.

(4) An internal pull-up holds this pin deasserted until the EEPROM is read.

NOTE

The direction of some pins (input vs. output) depends on the flags. In order to prevent conflicts on pins that may be both inputs and outputs, the AD1816 and AD1816A disable the output drivers for those pins while the flags are being read from the EEPROM, and keep them disabled if the EEPROM data is invalid.

PROGRAMMING EXTERNAL EEPROMS

Below are the details for programming an external EEPROM or an ADI-supplied PC Program may be used. The PnP EEPROM can be written only in the "Alternate Key State"; this prevents accidental EEPROM erasure when using standard PnP setup. The procedure for writing an EEPROM is:

- 1) Enter PnP configuration state and fully reset the part by writing 0x07 to PnP register 0x02. This step can be eliminated if the part has not been accessed since power-up, a previous full PnP reset or assertion of the ISA bus RESET signal.
- 2) Send the alternate initiation key to the PnP address port. EEPROM writes are disabled if the standard PnP key is used.
- 3) Enter isolation state and write a CSN to enter configuration state. Do not perform any isolation reads.
- 4) Poll PnP register 0x05 until it equals 0x01 and wait at least 336 microseconds (ensures that EEPROM is idle).
- 5) Write the second byte of your serial identifier to PnP register 0x20.
- 6) Read PnP register 0x04.
- 7) Wait for at least 464 microseconds, plus the EEPROM's write cycle time (up to 10 ms for a Xicor X24C02).
- 8) Repeat steps 4 through 7 for each byte in your PnP ROM, starting with the third byte of the serial identifier and ending with the final checksum byte. You must then continue to write filler bytes until 512 bytes, minus one more than the number of flag bytes, have been written. Finally, write the flag byte(s) (described above) and the first byte of the serial identifier.
- 9) Fully reset the part by writing 0x07 to PnP register 0x02.

The AD1816 or AD1816A will now act according to the contents of the EEPROM.

NOTES

Programming will not work if more than one part uses the same alternate initiation key in the system. Parts that use this alternate initiation key are the AD1816 and AD1816A.

If a 256-byte EEPROM is used, it is not necessary to wait 10 ms after writing bytes 255 to 511, because the EEPROM will ignore them anyway.

You can skip over bytes that you don't care to write by just performing a ROM read instead of a ROM write followed by a ROM read.

REFERENCE DESIGNS AND DEVICE DRIVERS

Reference designs and device drivers for the AD1816A are available via the Analog Devices Home Page on the World Wide Web at <http://www.analog.com>. Reference designs may also be obtained by contacting your local Analog Devices Sales representative or authorized distributor.

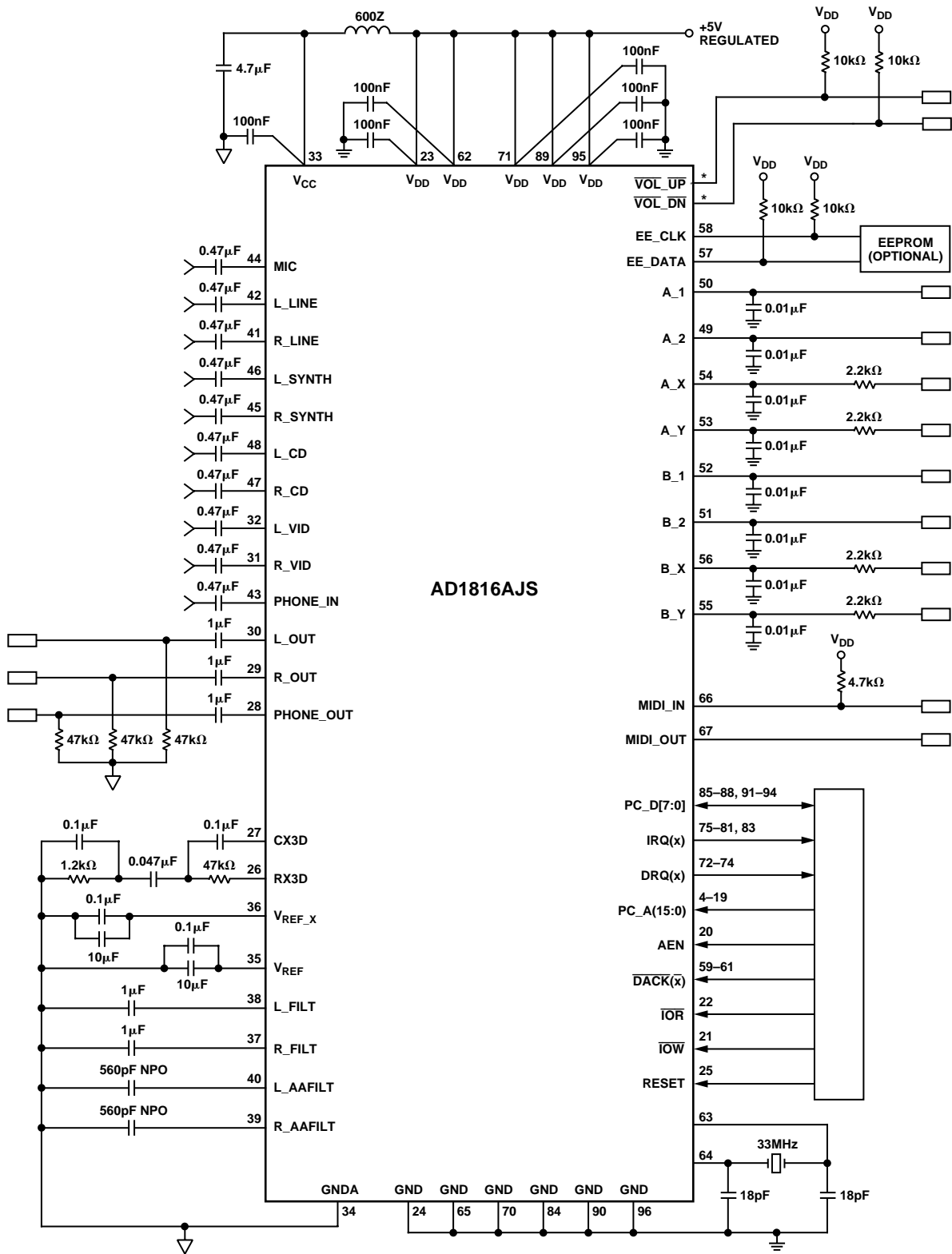

*LOCATION OF THIS PIN IS DETERMINED BY THE EEPROM

Figure 16. Recommended Application Circuit

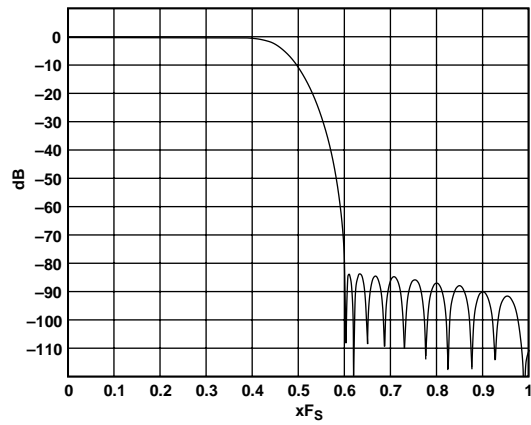

a. ADC Audio

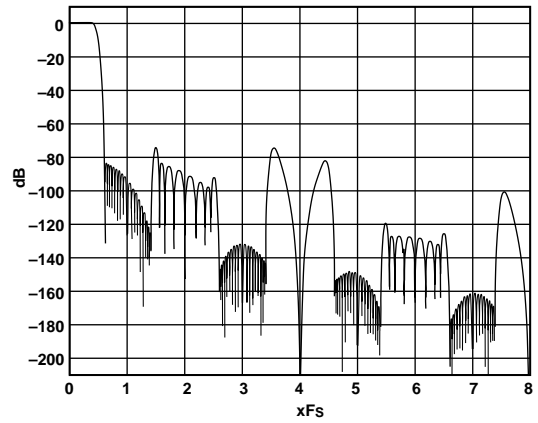

c. DAC Audio

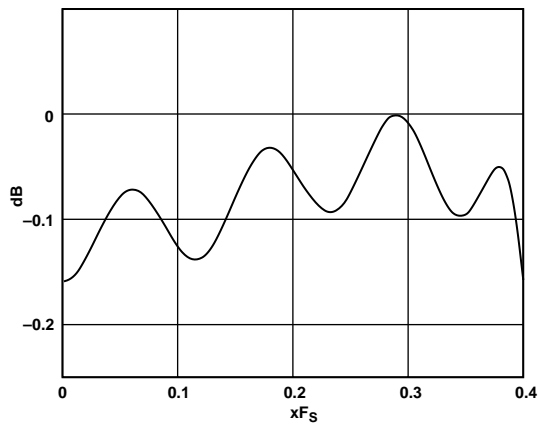

b. ADC Audio Passband

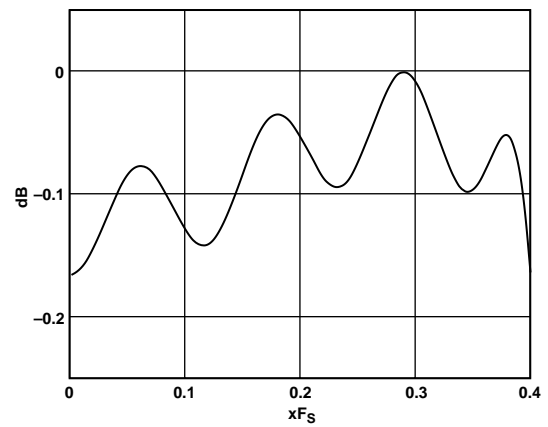

d. DAC Audio Passband (Including Out-of-Band Spectrum)

Figure 17. AD1816A Frequency Response Plots (Full-Scale Line-Level Input, 0 dB Gain). The Plots Do Not Reflect the Additional Benefits of the AD1816A Analog Filters. Out-of-Band Images Will Be Attenuated by an Additional 31.4 dB at 100 kHz.

OUTLINE DIMENSIONS

Dimensions shown in inches and (mm).

100-Lead Plastic Quad Flatpack (S-100)

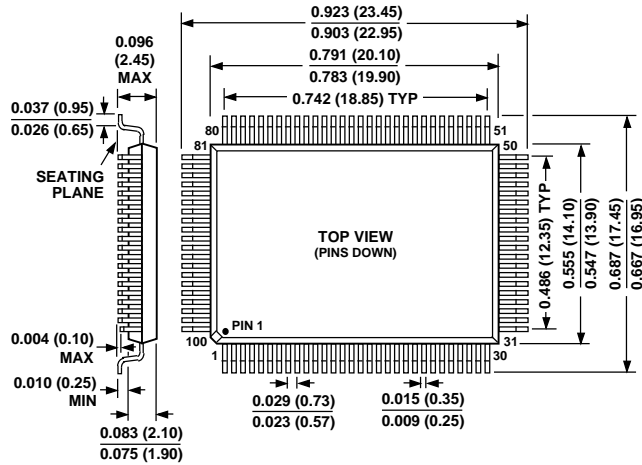

100-Lead Thin Quad Flatpack (ST-100)

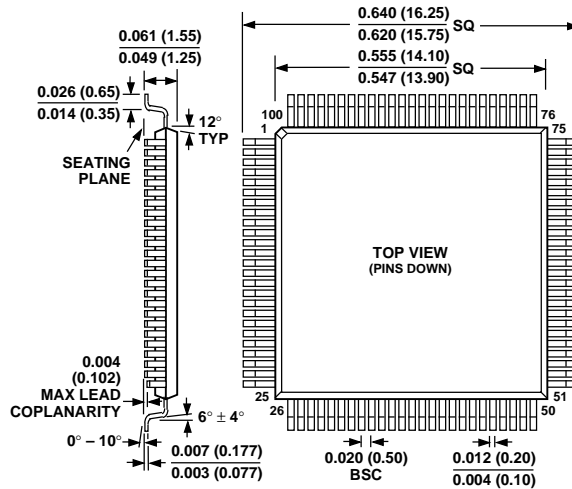

This datasheet has been download from:

www.datasheetcatalog.com

Datasheets for electronics components.